

# Compact multiprotocol I/O module for Ethernet

## 16 Digital PNP 2-A Outputs

### TBEN-LL-16DOP

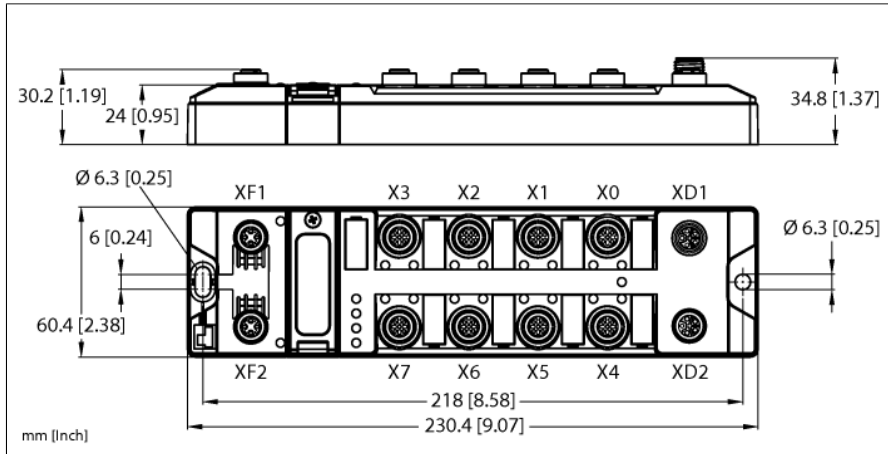

ID	100021342
<b>Supply</b>	
Supply voltage	24 VDC
Admissible range	18...30 VDC Pass-through current XD1–XD2 max. 16 A per voltage group Device current max. 9 A per voltage group Total current V1 + V2 max. 11 A UL derating for > 55 °C: Total current max. 6 A per voltage group
Voltage supply connection	M12, L-coded
Operating current	V1: max. 150 mA
Sensor/actuator supply	Slots X0–X7 supplied by V2 Short-circuit proof, 120 mA per slot
Electrical isolation	galvanic isolation of the voltage groups V1 and V2, voltages up to 500 VAC
Fault exclusion	Yes, acc. to EN ISO 13849-2, appendix D.2
Power dissipation, typical	≤ 10 W
<b>System data</b>	
Fieldbus transmission rate	10/100 Mbps
Fieldbus connection technology	2 x M12, 4-pin, D-coded
Protocol detection	automatic
Service interface	Ethernet via XF1 or XF2
BEEP functionality	Supported
ARGEE functionality	Supported
<b>Modbus TCP</b>	
Addressing	Static IP, DHCP
Supported function codes	FC1, FC2, FC3, FC4, FC6, FC15, FC16, FC23
Number of TCP connections	8
Input register start address	0 (0x0000 hex)
Output register start address	2048 (0x0800 hex)

- PROFINET device, EtherNet/IP device, Modbus TCP server, CC-Link IE field basic
- Integrated Ethernet switch
- Supports 10 Mbps/100 Mbps
- 2 x M12, 4-pin, D-coded, Ethernet fieldbus connection
- PROFINET S2 system redundancy
- Glass fiber reinforced housing
- Shock and vibration tested
- Fully potted module electronics
- Protection classes IP65, IP67, IP69K
- M12, 5-pin, L-coded male connector for power supply
- Galvanically isolated voltage groups support passive safety
- Max. 2 A per output
- Output diagnostics per channel
- Programmable ARGEE

Ethernet/IP	
Addressing	acc. to EtherNet/IP specification
Quick Connect (QC)	< 150 ms
min. RPI	2 ms
Device Level Ring (DLR)	supported
Class 3 connections (TCP)	3
Class 1 connections (CIP)	10
Input Assembly Instance	101
Output Assembly Instance	102
Configuration Assembly Instance	106



PROFINET	
Version	2.35
Addressing	DCP
Conformance class	B (RT)
MinCycleTime	1 ms
Fast Start-Up (FSU)	< 150 ms
Diagnostics	acc. to PROFINET alarm handling
Topology detection	supported
Automatic addressing	supported
Media Redundancy Protocol (MRP)	supported
System redundancy	S2
Netload class	3

CC-Link	
Interface	CC-Link IE Field Basic
Type	Intelligent device station
Message Transmission	Yes
Profile specification	CSP+
Max. occupied stations	2
IP change mechanism	Yes
Acyclic SLMP communication	Yes

Digital outputs	
Number of channels	16
Connectivity outputs	M12, 5-pin
Output type	PNP
Type of output diagnostics	Channel diagnostics
Output voltage	24 VDC from potential group
Output current per channel	2.0 A, short-circuit proof, max. 2.0 A per slot
Output delay	1.3 ms
Load type	EN 60947-5-1: DC-13
Short-circuit protection	yes
Electrical isolation	Galvanically isolated to the fieldbus Voltage proof up 500 VDC

Standard/Directive conformity	
Vibration test	Acc. to EN 60068-2-6 Acceleration up to 20 g
Shock test	acc. to EN 60068-2-27
Drop and topple	acc. to EN 60068-2-31/IEC 60068-2-32
Electromagnetic compatibility	Acc. to EN 61131-2
Approvals and certificates	CE and UKCA FCC statement, UV resistant acc. to DIN EN ISO 4892-2A (2013)
UL Certificate	cULus LISTED 21 W2, Encl.Type 1 IND.CONT.EQ.

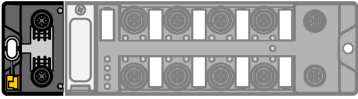
General Information	
Dimensions (W x L x H)	60.4 x 230.4 x 34.8 mm
Ambient temperature	-40...+70 °C
Storage temperature	-40...+85 °C
Altitude	Max. 5000 m
Protection class	IP65 IP67 IP69K
MTTF	148 years
Housing material	PA6-GF30
Housing color	Black
Connector material	Nickel-plated brass
Window material	Lexan
Material screw	303 stainless steel
Material label	Polycarbonate
Halogen-free	yes
Mounting	2 mounting holes □ 6.3 mm

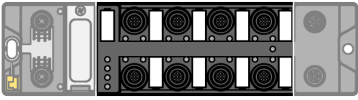
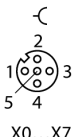
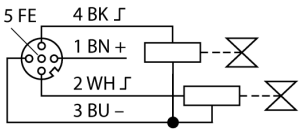
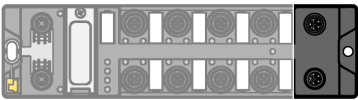
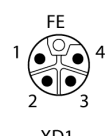
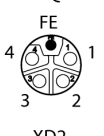
		<p>M12 × 1 Ethernet</p>  <p>1 = TX + 2 = RX + 3 = TX - 4 = RX - flange = FE</p> <p>XF1</p>  <p>1 = RX + 2 = TX + 3 = RX - 4 = TX - flange = FE</p> <p>XF2</p>
		<p>M12 × 1 Output</p>  <p>1 = Vaux2 2 = Signal Out 3 = GND V2 4 = Signal Out 5 = FE</p> <p>X0...X7</p>  <p>5 FE 4 BK J 1 BN + 2 WH J 3 BU -</p> <p>— X0...X7</p>
		<p>M12 power supply, L-coded</p>  <p>1 = 24VDC V1 2 = GND V2 3 = GND V1 4 = 24VDC V2 FE</p> <p>XD1</p>  <p>1 = 24VDC V1 2 = GND V1 3 = GND V2 4 = 24VDC V2 FE</p> <p>XD2</p>

## Module Status LED

LED	Color	Status	Description
L/A	Green	On	Ethernet link (100 Mbps)
		Flashing	Ethernet communication (100 Mbps)
	Yellow	On	Ethernet link (10 Mbps)
		Flashing	Ethernet communication (10 Mbps)
		Off	No Ethernet link
BUS	Green	On	Active connection to a client
		Flashing	Steady flashing: ready for operation Sequence of 3 flashes in 2 seconds: FLC/ARGEE active
	Red	On	IP address conflict or Restore mode or Modbus timeout
		Flashing	Blink/Wink command active
	Green/red	Alternating	Autonegotiation and/or waiting for DHCP/Boot-P addressing
		Off	Power off
ERR	Green	On	No diagnostics available
	Red	On	Diagnostics available
PWR	LED response parameter (PWR) at $V_2$ undervoltage = "red"		
	Green	On	$V_1$ and $V_2$ power supply OK
	Red	On	$V_2$ power supply off or $V_2$ undervoltage
		Off	$V_1$ power supply off or $V_1$ undervoltage
	LED response parameter (PWR) at $V_2$ undervoltage = "green"		
	Green	On	$V_1$ and $V_2$ power supply OK
		Flashing	$V_2$ power supply off or $V_2$ undervoltage
		Off	$V_1$ power supply off or $V_1$ undervoltage

## LED Status I/O

LED	Color	Status	Description
LED 0 ... 15	Green	ON	Output active
		Flashing	Power overload at the corresponding port. Both port LEDs are flashing.
	Red	ON	Output active with overload/short circuit
		OFF	Output inactive

**Process Data Mapping of the Single Protocols**

For more details on the corresponding protocols see manual.