

NI30U-M30E-AP6X-H1141

Inductive Sensor – With Extended Switching Distance

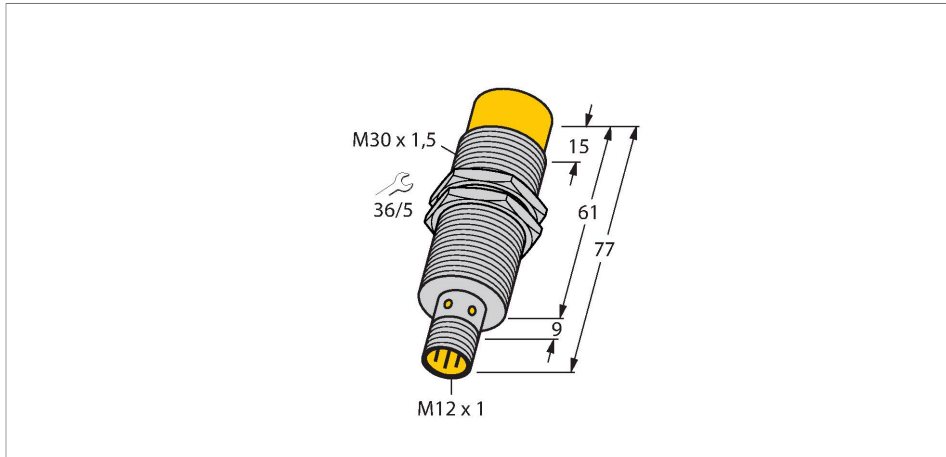

Technical data

Type	NI30U-M30E-AP6X-H1141
ID	1644756
General data	
Rated switching distance	30 mm
Mounting conditions	Non-flush
Secured operating distance	$\leq (0.81 \times S_n)$ mm
Repeat accuracy	$\leq 2 \%$ of full scale
Temperature drift	$\leq \pm 10 \%$
	$\leq \pm 15 \%$, $\leq -25 \text{ }^\circ\text{C}$ v $\geq +70 \text{ }^\circ\text{C}$
Hysteresis	3...15 %
Electrical data	
Operating voltage U_B	10...30 VDC
Ripple U_{ss}	$\leq 10 \%$ U_{Bmax}
DC rated operating current I_e	≤ 200 mA
No-load current	≤ 25 mA
Residual current	≤ 0.1 mA
Isolation test voltage	0.5 kV
Short-circuit protection	yes/Cyclic
Voltage drop at I_e	≤ 1.8 V
Wire break/reverse polarity protection	yes/Complete
Output function	3-wire, NO contact, PNP
DC field stability	300 mT
AC field stability	300 mT _{ss}
Insulation class	□

Features

- Threaded barrel, M30 x 1.5
- Long version
- Chrome-plated brass
- Factor 1 for all metals
- Protection class IP68
- Resistant to magnetic fields
- Large switching distance
- Integrated protection against predamping
- Little metal-free spaces
- DC 3-wire, 10...30 VDC
- NO contact, PNP output
- M12 x 1 male connector

Wiring diagram

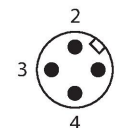
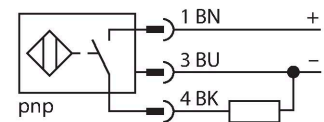

Functional principle

Inductive sensors are designed for wear-free and contactless detection of metal objects. uprox+ sensors have significant advantages due to their patented multi-coil system. They

Technical data

excel thanks to their optimum switching distances, maximum flexibility and operational reliability as well as efficient standardization.

Switching frequency	1 kHz
Mechanical data	
Design	Threaded barrel, M30 x 1.5
Dimensions	77 mm
Housing material	Metal, CuZn, Chrome-plated
Active area material	Plastic, LCP
Max. tightening torque of housing nut	75 Nm
Electrical connection	Connector, M12 x 1
Environmental conditions	
Ambient temperature	-30...+85 °C
Vibration resistance	55 Hz (1 mm)
Shock resistance	30 g (11 ms)
Protection class	IP68
MTTF	874 years acc. to SN 29500 (Ed. 99) 40 °C
Switching state	LED, Yellow

Mounting instructions

Mounting instructions/Description

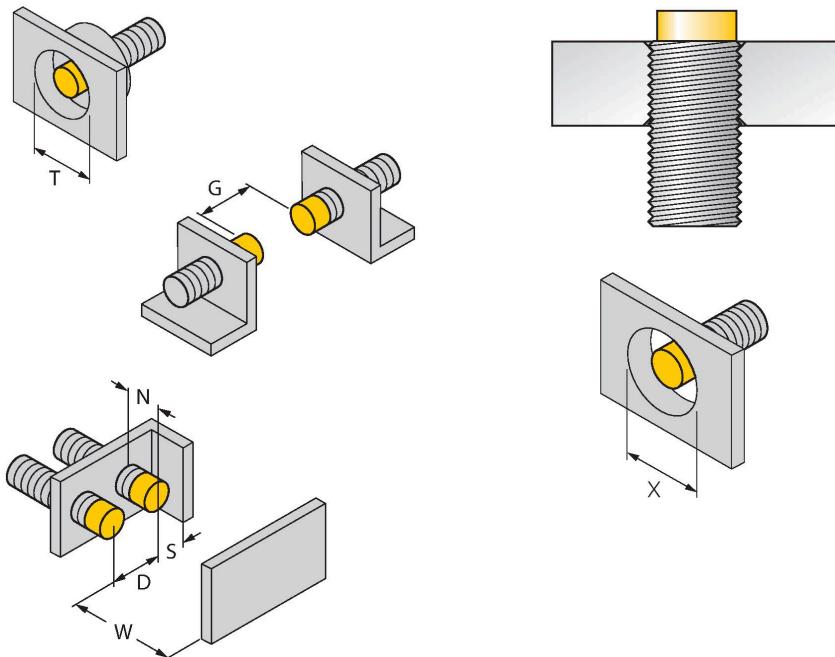

Distance D	135 mm
Distance W	3 x Sn
Distance T	3 x B
Distance S	1.5 x B
Distance G	6 x Sn
Distance N	2 x Sn
Diameter active area B	Ø 30 mm

All non-flush mountable aprox®+ threaded barrel sensors can be screwed to the upper edge of the barrel. In this mounting position, the sensor operates safely with a 20 % reduced switching distance.

When installed in an aperture plate, a distance of X = 140 mm must be observed.

Accessories

QM-30

6945103

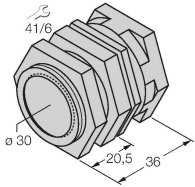

Quick-mount bracket with dead-stop; material: Chrome-plated brass. Male thread M36 × 1.5. Note: The switching distance of the proximity switches may change when using quick-mount brackets.

BST-30B

6947216

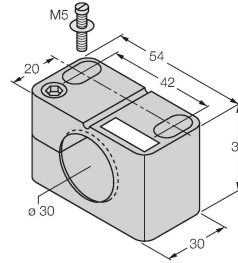

Mounting clamp for threaded barrel sensors, with dead-stop; material: PA6

MW30

6945005

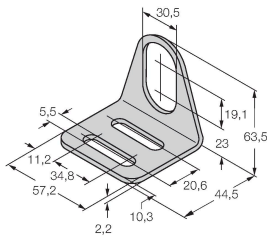

Mounting bracket for threaded barrel sensors; material: Stainless steel A2 1.4301 (AISI 304)

BSS-30

6901319

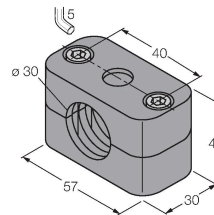

Mounting clamp for smooth and threaded barrel sensors; material: Polypropylene