

# NI12U-MT18-AP6X2-H1141/S395/S1589

## Inductive Sensor – With WeldGuard™ coating

### Features

- M18 x 1 threaded barrel
- Brass, PTFE-coated
- Factor 1 for all metals
- Protection class IP68
- Resistant to magnetic fields
- Extended temperature range
- High switching frequency
- DC 3-wire, 10...30 VDC
- NO contact, PNP output
- M12 x 1 male connector

### Wiring diagram

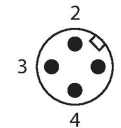
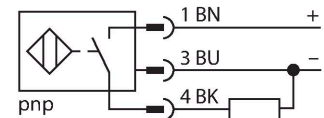

### Functional principle

Inductive sensors are designed for wear-free and contactless detection of metal objects. Approx Factor 1 sensors have significant advantages due to their patented ferrite-coreless 3-coil system. They detect all metals at the same large switching distance and are resistant to magnetic fields. Turck WeldGuard sensors for use in welding systems are equipped with a thin coating made of thermosetting plastic. This high-tech coating is resistant to abrasion and withstands mechanical stress.

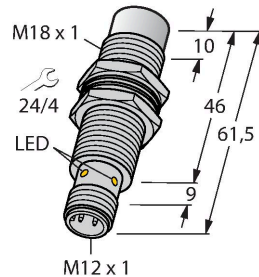

### Technical data

Type	NI12U-MT18-AP6X2-H1141/S395/S1589
ID	1645291
Special version	S395-S1589 Corresponds to: Housing length: 61.5 mm; thread length: 36 mm thread length; with WeldGuard™ coating
<b>General data</b>	
Rated switching distance	12 mm
Mounting conditions	Non-flush
Secured operating distance	$\leq (0.81 \times S_n)$ mm
Repeat accuracy	$\leq 2\%$ of full scale
	$\leq \pm 15\%$ , $\leq -25\text{ °C}$ v $\geq +70\text{ °C}$
Hysteresis	3...15 %
<b>Electrical data</b>	
Operating voltage $U_b$	10...30 VDC
Ripple $U_{ss}$	$\leq 10\%$ $U_{Bmax}$
DC rated operating current $I_b$	$\leq 200$ mA
No-load current	$\leq 25$ mA
Residual current	$\leq 0.1$ mA
Isolation test voltage	0.5 kV
Short-circuit protection	yes/Cyclic
Voltage drop at $I_b$	$\leq 1.8$ V
Wire break/reverse polarity protection	yes/Complete
Output function	3-wire, NO contact, PNP
DC field stability	300 mT
AC field stability	300 mT <sub>ss</sub>

## Technical data

Insulation class	□
Switching frequency	1 kHz
<b>Mechanical data</b>	
Design	Threaded barrel, M18 x 1
Dimensions	61.5 mm
Housing material	Metal, CuZn, PTFE-coated
Active area material	Plastic, PBT + WeldGuard™, PTFE-coated
Max. tightening torque of housing nut	15 Nm
Electrical connection	Connector, M12 × 1
<b>Environmental conditions</b>	
Ambient temperature	-30...+85 °C
Vibration resistance	55 Hz (1 mm)
Shock resistance	30 g (11 ms)
Protection class	IP68
MTTF	874 years acc. to SN 29500 (Ed. 99) 40 °C
Power-on indication	LED, Green
Switching state	LED, Yellow

## Mounting instructions

### Mounting instructions/Description

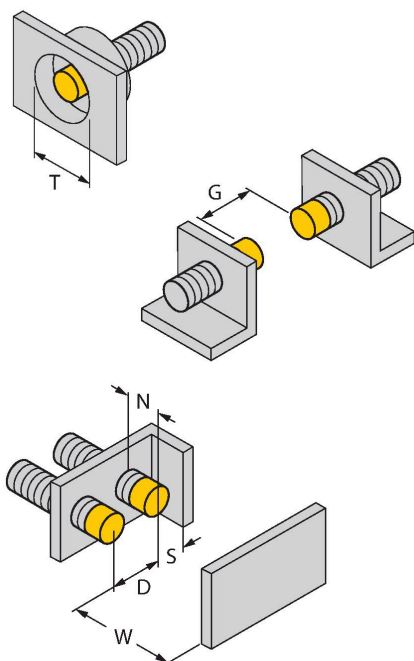

Distance D	3 x B
Distance W	3 x Sn
Distance T	3 x B
Distance S	1.5 x B
Distance G	6 x Sn
Distance N	2 x Sn
Diameter active area B	Ø 18 mm

## Accessories

BST-18B

6947214

Mounting clamp for threaded barrel sensors, with dead-stop; material: PA6

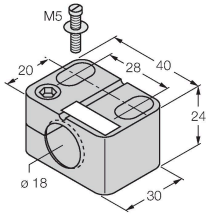

QMT-18

6945104

Quick-mount bracket with dead-stop; material: brass, PTFE-coated; Male thread M24 × 1.5. Note: The switching distance of the proximity switches may change when using quick-mount brackets.



QM-18

6945102

Quick-mount bracket with dead-stop; material: Chrome-plated brass. Male thread M24 × 1.5. Note: The switching distance of the proximity switches may change when using quick-mount brackets.

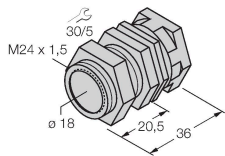

BSS-18

6901320

Mounting clamp for smooth and threaded barrel sensors; material: Polypropylene

