

SPECIFICATIONS	
HOUSING MATERIAL	DIE-CAST ALUMINUM ALLOY
HOUSING FINISH/COLOR	POWDER COAT/BLACK
RECEPTACLE HOUSING MAT'L/FINISH	STAINLESS STEEL/PASSIVATED
CONTACT CARRIERS MATERIAL	TPU
CONTACTS MATERIAL/PLATING	BRASS/GOLD
OPERATING VOLTAGE	300 V
OPERATING CURRENT	4.0 A PER CONDUCTOR
PROTECTION CLASS to DIN 40050	IP 67 - ONLY WHEN ALL RECEPTACLES ARE COVERED WITH PLUGS OR CONNECTED
OPERATING TEMPERATURE	-40°C to +70°C (-40°F to +158°F)

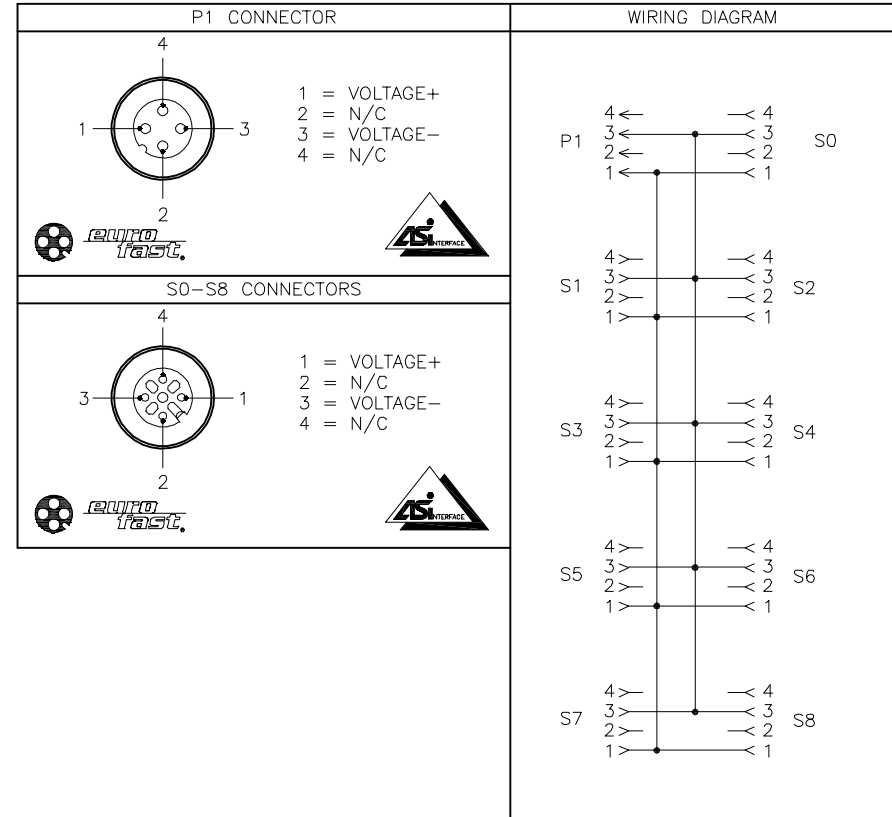

SOURCE DRAWING - FOR REFERENCE ONLY

RELATED DOCUMENTS 1. 2. 3. 4.	3RD ANGLE PROJECTION 	THIS DRAWING IS CONFIDENTIAL AND THE PROPERTY OF TURCK INC. USE OF THIS DOCUMENT WITHOUT WRITTEN PERMISSION IS PROHIBITED.		3000 CAMPUS DRIVE MINNEAPOLIS, MN 55441 1-800-544-7769 (763) 553-7300 (763) 553-0708 fax www.turck.us	
	MATERIAL	DRFT RDS	DATE 04/18/07	DESCRIPTION JBBS-25-E813	
FINISH	ALL DIMENSIONS DISPLAYED ON THIS DRAWING ARE FOR REFERENCE ONLY  CONTACT TURCK FOR MORE INFORMATION	APVD	SCALE 1=2.0	IDENTIFICATION NO. U3-00854	
		UNIT OF MEASUREMENT <b>MILLIMETER [ INCH ]</b>		REV D	
D ADD CE-UKCA MARK TO CLICHE	RDS	08/18/22	500000006082	DO NOT SCALE THIS DRAWING	
REV DESCRIPTION	BY	DATE	ECO NO.	FILE: U3-00854	SHEET 1 OF 1