

BL compact™ multiprotocol fieldbus station for Industrial Ethernet

SSI Interface

BLCEN-1M12MT-1SSI

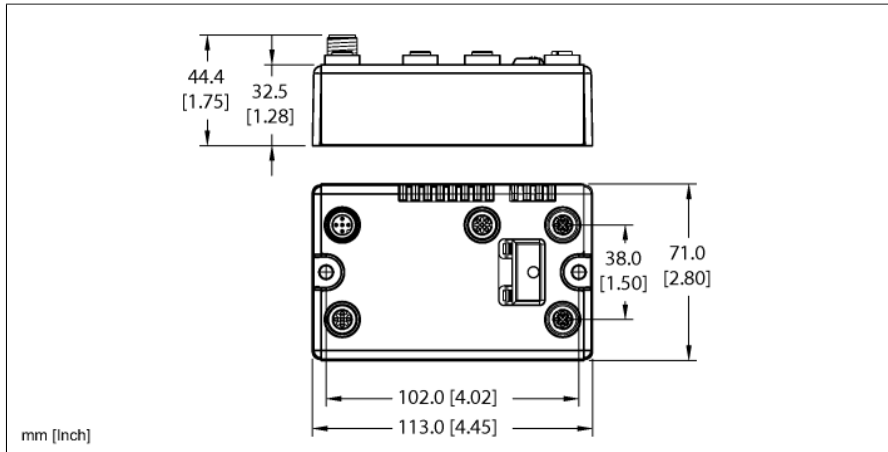

ID	6811460
Nominal system voltage	24 VDC
System power supply	Via auxiliary power
Voltage supply connection	2 x M12, 5-pin
Admissible range Vi	18...30 VDC
Nominal current Vi	150 mA
Max. current Vi	1 A
Fieldbus transmission rate	10/100 Mbps
Adjustment transmission rate	Automatic detection
Fieldbus address range	1...92 0 (192.168.1.254) 93 (BOOTP) 94 (DHCP) 95 (PGM) 96 (PGM-DHCP) *recommended for PROFINET 97...98 (manufacturer specific)
Fieldbus addressing	2 decimally coded rotary switches
Fieldbus connection technology	2 x M12 4-pole, D-coded
Protocol detection	automatic
Web server	Integrated
Service interface	Ethernet
Vendor ID	48
Product type	12
Product code	11460
Modbus TCP	
Addressing	Static IP, BOOTP, DHCP
Supported function codes	FC1, FC2, FC3, FC4, FC5, FC6, FC15, FC16, FC23
Number of TCP connections	6
Input Data Size	max. 6 register
Input register start address	0 (0x0000 hex)
Output Data Size	max. 4 register
Output register start address	2048 (0x0800 hex)

- On-machine Compact fieldbus I/O block
- EtherNet/IP™, Modbus® TCP, or PROFINET slave
- Integrated Ethernet Switch
- 10 Mbps / 100 Mbps supported
- Two 4-pole M12, D-coded, connectors for fieldbus connection
- 2 rotary switches for node address
- IP67, IP69K
- M12 I/O connectors
- LEDs indicating status and diagnostics
- Electronics galvanically separated from the field level via optocouplers
- Connection of SSI encoder
- Max transmission rate of 1 Mbps

Ethernet/IP	
Addressing	acc. to EtherNet/IP specification
Device Level Ring (DLR)	supported
Class 1 connections (CIP)	6
Input Assembly Instance	103
Input Data Size	6 INT
Output Assembly Instance	104
Output Data Size	4 INT
Configuration Assembly Instance	106
Configuration Size	0
Comm Format	Data - INT

PROFINET	
Addressing	DCP
Conformance class	B (RT)
MinCycleTime	1 ms
Diagnostics	acc. to PROFINET alarm handling
Topology detection	supported
Automatic addressing	supported
Media Redundancy Protocol (MRP)	supported
Input Data Size	max. 8 BYTE
Output Data Size	max. 8 BYTE

Technology	
Signal type	Synchronous serial interface
Number of channels	1
Transmission signals	CL, D
Connection type	4-wire full duplex (clock output/signal input)
Cable length	30 m
Parameters	transmission rate, diagnostics, data format (binary / GRAY coded), data frame bits (1-32), number of invalid bits (LSB: 0-15, MSB: 0-7)
Electrical isolation	isolation of electronics and field level via optocouplers

Dimensions	113 x 71 x 32.5 mm
Mounting	2 x 5.4 mm diameter holes, 1.7 Nm torque
Weight	330 ± 20 g
Housing material	Glass-filled nylon, nickel plated brass connectors
Housing color	Black
Material screw	Nickel-plated brass
Material label	Polyester with polycarbonate overlay
Ground label material	Nickel plated brass
Protection class	IP67 IP69K
Ambient temperature	-40...+70 °C
Storage temperature	-40...+85 °C
Relative humidity	15 to 95% (non-condensing)
Vibration test	Acc. to IEC 61131-2
- up to 20 g (at 10 up to 150 Hz)	For mounting on base plate or machinery
Shock test	according to IEC 61131-2
Electromagnetic compatibility	Acc. to IEC 61131-2
MTTF	176 years
MTTF note	acc. to SN 29500 (Ed. 99) 20 °C
Approvals and certificates	CE, cULus

Pinning and wiring diagram

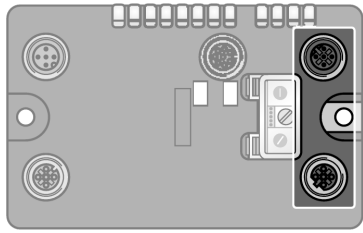

Ethernet

Fieldbus cable (IP67 example): RSSD RSSD 441-2M ID number U-02482 or RSSD-RSSD-441-2M/S2174 ID number 6914218

Pin Assignment (M12, D-code)

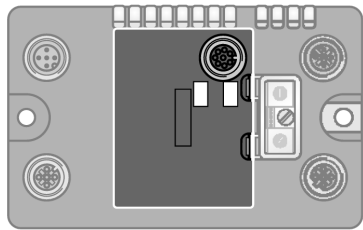
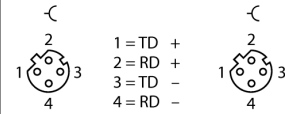

SSI Interface

Extension cable (example): RKC 8T-2-RSC 8T/S1555 ident-no. U0933-01 or BS8181-0 ident-no. 6901004

Pin Assignment

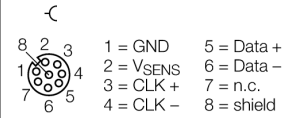

Wiring Diagram

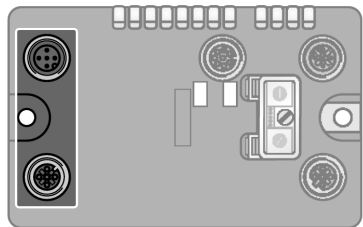
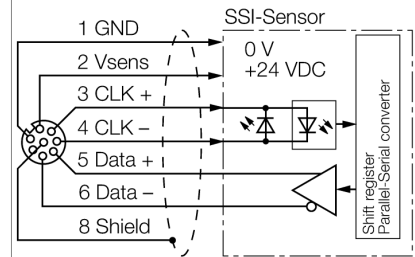

Auxiliary Power

Extension cable (example): RKC 4.4T-2-RSC 4.4T ident-no. U5264 or RKC4.4T-2-RSC4.4T/TEL ident-no. 6625208

Pin Assignment

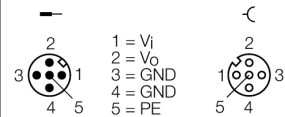

Station LED status

LED	Color	Status	Description
IOs		OFF	No power
	RED	ON	Low power or station error
	RED	FLASHING (1 Hz)	I/O module configuration error
	RED	FLASHING (4 Hz)	No I/O module bus communication
	GREEN	ON	Station ok
	GREEN	FLASHING	Force mode active
BUS		OFF	Power Off
	GREEN	ON	Connected to Master
	GREEN	FLASHING	Ready
	RED	ON	Error
	RED	FLASHING	WINK
	YELLOW	ON	DHCP/BOOTP Search
LNK/ACT		OFF	No Link
	GREEN	ON	Link
	GREEN	FLASHING	Traffic
	YELLOW	ON	100 Mbit Linked

I/O LED status

LED	Color	Status	Description
D *		OFF	No diagnostics active
	RED	ON	Station error/ module bus communication failure
	RED	FLASHING (0.5Hz)	Diagnostics active
UP		OFF	No upwards direction of movement
	GREEN	ON	Direction of movement upwards
DN		OFF	No downwards direction of movement
	GREEN	ON	Direction of movement downwards

* D LED also indicates gateway diagnostics

Process Data Mapping of Each Protocol

EtherNet/IP™ I/O & Diagnostics Data Mapping

INPUT	BYTE	Bit 7	Bit 6	Bit 5	Bit 4	Bit 3	Bit 2	Bit 1	Bit 0
Status Bytes	0	STS_STOP	-	-	ERR_PARA	STS_UFLW	STS_OFLW	ERR_SSI	SSI_DIAG
	1	STS_UP	STS_DN	REL_CMP2	FLAG_CMP2	STS_CMP2	REL_CMP1	FLAG_CMP1	STS_CMP1
	2	REG_WR_ACCEPT	REG_WR_AKN	-	-	SSI_STS3	SSI_STS2	SSI_STS1	SSI_STS0
Communication	3	REG_RD_ABORT		REG_RD_ADR					
User Data	4	REG_RD_DATA, Byte 0							
	5	REG_RD_DATA, Byte 1							
	6	REG_RD_DATA, Byte 2							
	7	REG_RD_DATA, Byte 3							
Diagnostics	8	Module number reporting diagnostic data							
	9	Replace Station	-	Diagnostics Active	-	-	-	-	-
Slot 1 (ref. Byte 8)	10	-	-	-	Parameterization Error	Sensor Value Underflow	Sensor Value Overflow	Open Circuit	SSI Group Diagnostics
	11	-	-	-	-	-	-	-	-
OUTPUT	BYTE	Bit 7	Bit 6	Bit 5	Bit 4	Bit 3	Bit 2	Bit 1	Bit 0
Control Bytes	0	STOP	-	-	-	-	-	-	-
	1	-	-	-	CLR_CMP2	EN_CMP2	-	CLR_CMP1	EN_CMP1
	2	REG_WR	-	REG_WR_ADR					
Communication	3	-	-	REG_RD_ADR					
User Data	4	REG_WR_DATA, Byte 0							
	5	REG_WR_DATA, Byte 1							
	6	REG_WR_DATA, Byte 2							
	7	REG_WR_DATA, Byte 3							

Modbus® TCP Register Mapping

	REG	Bit 15	Bit 14	Bit 13	Bit 12	Bit 11	Bit 10	Bit 9	Bit 8	Bit 7	Bit 6	Bit 5	Bit 4	Bit 3	Bit 2	Bit 1	Bit 0
Inputs (RO)	0x0000	STS UP	STS DN	REL_CMP2	FLAG_CMP2	STS_CMP2	REL_CMP1	FLAG_CMP1	STS_CMP1	STS_STOP	-	-	ERR_PARA	STS_UFLW	STS_OFLW	ERR_SSI	SSI_DIAG
	0x0001	REG_RD_ABORT	-	REG_RD_ADR						REG_WR_ACCEPT	REG_WR_AKN	-	-	SSI_STS3	SSI_STS2	SSI_STS1	SSI_STS0
	0x0002 ... 0x0003	REG_RD_DATA (2 Words)															
Status (RO)	0x0004	-	FCE	-	-	CFG	COM	VI low	-	VO low	-	-	-	-	-	-	DIA
Diag. (RO)	0x0005	-	-	-	-	-	-	-	-	-	-	-	-	-	-	-	S1 DIA
Outputs (RW)	0x0800	-	-	-	CLR_CMP2	EN_CMP2	-	CLR_CMP1	EN_CMP1	STOP	-	-	-	-	-	-	-
	0x0801	-	REG_RD_ADR						REG_WR	-	REG_WR_ADR						
	0x0802 ... 0x0803	REG_WR_DATA (2 Words)															
I/O Diag. (RO)	0xA000	-	-	-	-	-	-	-	-	-	-	-	CFG	UF SSI	OF SSI	OC SSI	GRP

PROFINET® Process Data

	BYTE	Bit 7	Bit 6	Bit 5	Bit 4	Bit 3	Bit 2	Bit 1	Bit 0	
Inputs	0	STS_STOP	-	-	ERR_PARA	STS_UFLW	STS_OFLW	ERR_SSI	SSI_DIAG	
	1	STS_UP	STS_DN	REL_CMP2	FLAG_CMP2	STS_CMP2	REL_CMP1	FLAG_CMP1	STS_CMP1	
	2	REG_WR_ACCEPT	REG_WR_AKN	-	-	SSI_STS3	SSI_STS2	SSI_STS1	SSI_STS0	
	3	REG_RD_ABORT		REG_RD_ADR						
	4	REG_RD_DATA, Byte 0								
	5	REG_RD_DATA, Byte 1								
	6	REG_RD_DATA, Byte 2								
Outputs	0	STOP	-	-	-	-	-	-	-	
	1	-	-	-	CLR_CMP2	EN_CMP2	-	CLR_CMP1	EN_CMP1	
	2	REG_WR	-	REG_WR_ADR						
	3	-	-	REG_RD_ADR						
	4	REG_WR_DATA, Byte 0								
	5	REG_WR_DATA, Byte 1								
	6	REG_WR_DATA, Byte 2								
7	REG_WR_DATA, Byte 3									