

# WIRING DIAGRAM

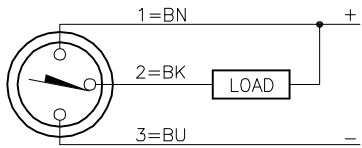

OUTPUT: AN6X

SHORT-CIRCUIT AND OVERLOAD PROTECTED

# SPECIFICATIONS

PASS SPEED	≤ 10 m/s
HYSTERESIS	≤ 1mm
TEMPERATURE DRIFT	≤ 0.1mm
MIN. ABSOLUTE REPEAT ACCURACY	≥ ±0.1mm
OPERATING TEMPERATURE	-25°C to +70°C (-13°F to +158°F)
RATED OPERATIONAL VOLTAGE	10-30 VDC
MAX. RIPPLE	≤ 10%
DC RATED OPERATIONAL CURRENT	≤ 150 mA
NO-LOAD CURRENT	≤ 15 mA
RESIDUAL CURRENT	≤ 0.1 mA
MAX. SWITCHING FREQUENCY	≤ 1.0 kHz
RATED INSULATION VOLTAGE	≤ 0.5 kV
OUTPUT FUNCTION	NORMALLY OPEN, 3-WIRE, NPN
SHORT-CIRCUIT PROTECTION	YES, CYCLIC
MAX. VOLTAGE DROP	≤ 1.8 V
WIRE BREAKAGE PROTECTION	INCORPORATED
REVERSE POLARITY PROTECTION	INCORPORATED
HOUSING MATERIAL	PLASTIC, PP
ACTIVE FACE MATERIAL	PLASTIC, PP
CABLE	ø3.0, LifYY-11Y, TPU
VIBRATION	55 Hz, 1 mm AMPLITUDE (IN ALL 3 PLANES)
SHOCK	30 g, 11 ms
DEGREE OF PROTECTION	IP68
SWITCHING STATUS INDICATION	LED, YELLOW
INCLUDED IN SCOPE OF SUPPLY	CABLE CLIP

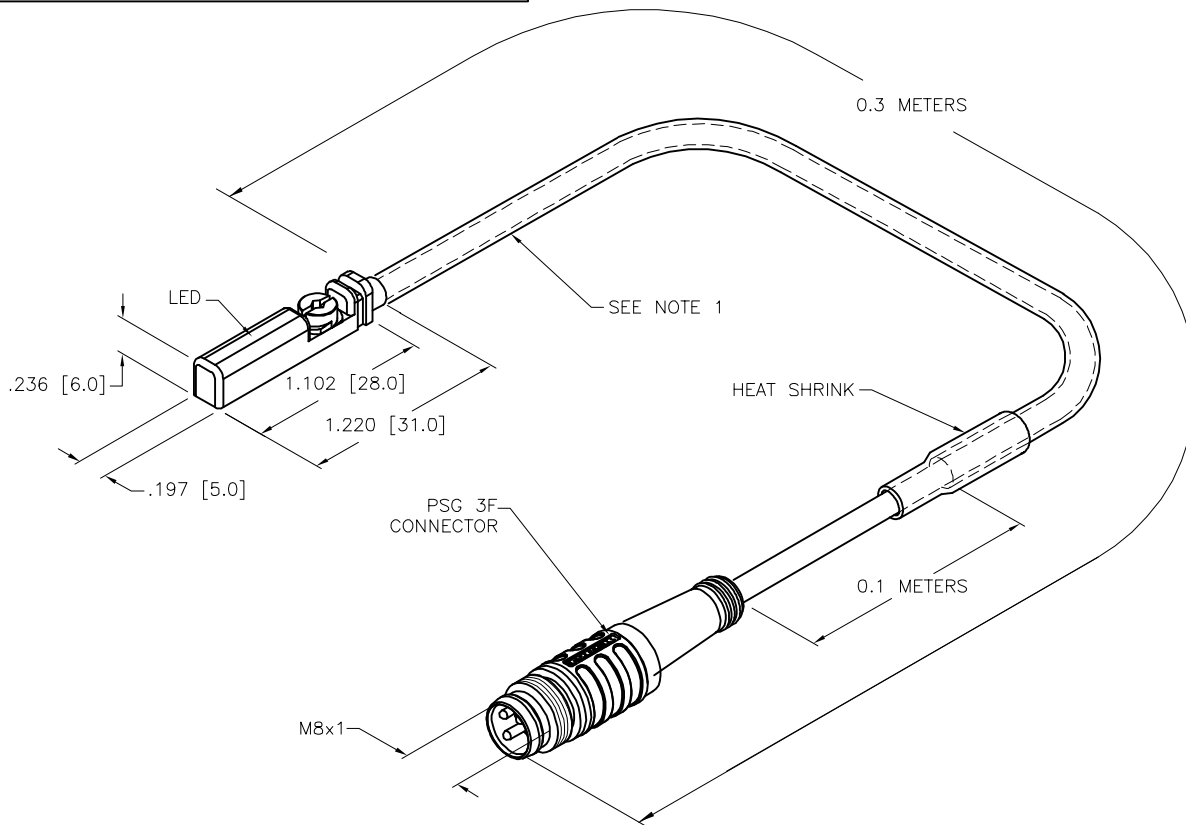

### NOTES:

1. "/S1764" WELDGUARD COATED SENSOR WITH FIREFAST VITON SLEEVING. SLEEVE STARTS ON SENSOR END, AND COVERS ALL BUT 100MM OF CABLE HELD IN PLACE BY SHRINK TUBE.

SOURCE DRAWING - FOR REFERENCE ONLY

RELATED DOCUMENTS 1. 2. 3. 4.	3RD ANGLE PROJECTION 	THIS DRAWING IS CONFIDENTIAL AND THE PROPERTY OF TURCK INC. USE OF THIS DOCUMENT WITHOUT WRITTEN PERMISSION IS PROHIBITED.		3000 CAMPUS DRIVE MINNEAPOLIS, MN 55441 1-800-544-7769 (763) 553-7300 (763) 553-0708 fax www.turck.us	
	MATERIAL	DRFT RDS	DATE 09/19/18	DESCRIPTION BIM-UNT-AN6X-0.3-PSG3F/S1764	
FINISH	ALL DIMENSIONS DISPLAYED ON THIS DRAWING ARE FOR REFERENCE ONLY	APVD A.F.	SCALE 1=1.0	IDENTIFICATION NO. 4685989	
CONTACT TURCK FOR MORE INFORMATION		UNIT OF MEASUREMENT <b>INCH [ MILLIMETER ]</b>		REV B	
DO NOT SCALE THIS DRAWING		FILE: 4685989		SHEET 1 OF 1	

B	UPDATE SENSOR BODY AND PROTECTION CLASS	RDS	02/11/21	76491
REV	DESCRIPTION	BY	DATE	ECO NO.