

WIRING DIAGRAM

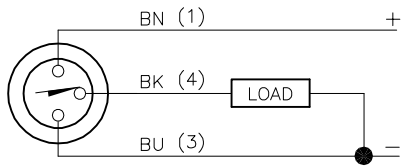

OUTPUT: AP6X

SHORT-CIRCUIT AND OVERLOAD PROTECTED

SPECIFICATIONS PER SENSOR

PASS SPEED	≤ 0.3 m/s
HYSTERESIS	≤ 1mm
TEMPERATURE DRIFT	≤ 0.1mm
MIN. ABSOLUTE REPEAT ACCURACY	≥ ±0.1mm
OPERATING TEMPERATURE	-25°C to +70°C (-13°F to +158°F)
RATED OPERATIONAL VOLTAGE	10-30 VDC
RESIDUAL RIPPLE	≤ 10%
DC RATED OPERATIONAL CURRENT	≤ 100 mA
NO-LOAD CURRENT	≤ 15 mA
RESIDUAL CURRENT	≤ 0.1 mA
MAX. SWITCHING FREQUENCY	≤ 0.02 kHz
RATED INSULATION VOLTAGE	≤ 0.5 kV
OUTPUT FUNCTION	NORMALLY OPEN, 3-WIRE, PNP
SHORT-CIRCUIT PROTECTION	YES, CYCLIC
MAX. VOLTAGE DROP	≤ 1.8 V
WIRE BREAKAGE PROTECTION	INCORPORATED
REVERSE POLARITY PROTECTION	INCORPORATED
HOUSING MATERIAL	PLASTIC, PP
ACTIVE FACE MATERIAL	PLASTIC, PP
CABLE	∅2.0, TPU/GRAY
VIBRATION	55 Hz, 1 mm AMPLITUDE (IN ALL 3 PLANES)
SHOCK	30 g, 11 ms
DEGREE OF PROTECTION	IP67
SWITCHING STATUS INDICATION	LED, YELLOW
INCLUDED IN SCOPE OF SUPPLY	CABLE CLIP

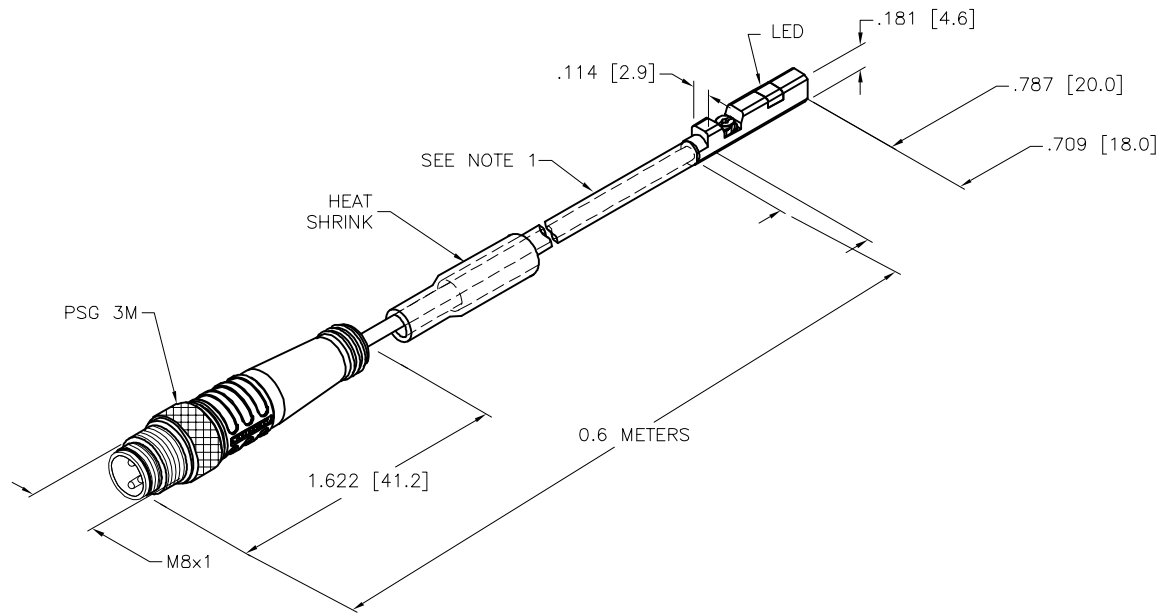

1. "/S1764" WELDGUARD COATED SENSOR WITH FIREFAST VITON SLEEVING. SLEEVE STARTS ON SENSOR END, AND COVERS ALL BUT 100MM OF CABLE HELD IN PLACE BY SHRINK TUBE.

SOURCE DRAWING - FOR REFERENCE ONLY

RELATED DOCUMENTS 1. 2. 3. 4.	3RD ANGLE PROJECTION 	THIS DRAWING IS CONFIDENTIAL AND THE PROPERTY OF TURCK INC. USE OF THIS DOCUMENT WITHOUT WRITTEN PERMISSION IS PROHIBITED.		3000 CAMPUS DRIVE MINNEAPOLIS, MN 55441 1-800-544-7769 (763) 553-7300 (763) 553-0708 fax www.turck.us	
	MATERIAL SEE SPECIFICATIONS	ALL DIMENSIONS DISPLAYED ON THIS DRAWING ARE FOR REFERENCE ONLY CONTACT TURCK FOR MORE INFORMATION	DRFT KMY DATE 06/21/13	DESCRIPTION BIM-UNR-AP6X-0.6-PSG3M/S1764 W/M	
FINISH SEE SPECIFICATIONS	APVD A.F. SCALE 1=1.0		UNIT OF MEASUREMENT INCH [MILLIMETER]		IDENTIFICATION NO. 46858429
DO NOT SCALE THIS DRAWING		FILE: 46858429		SHEET 1 OF 2	

D	UPDATE SPECS	NF	06/16/25	81245
REV	DESCRIPTION	BY	DATE	ECO NO.