

### WIRING DIAGRAM

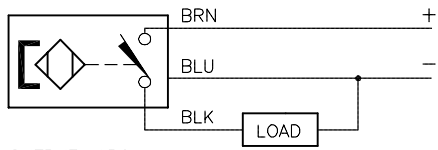

SHORT-CIRCUIT AND OVERLOAD PROTECTED

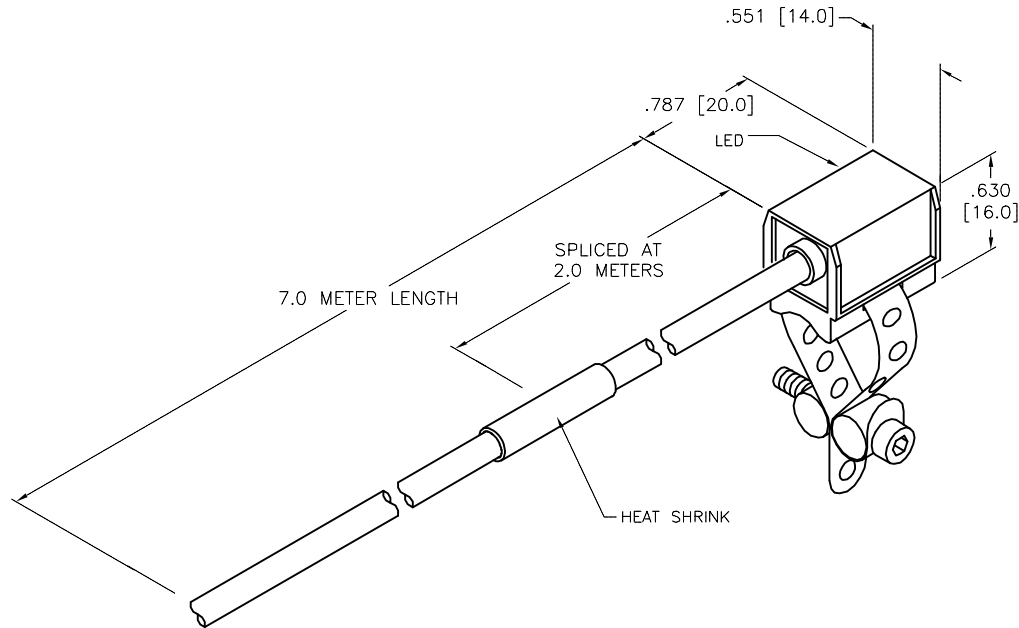

### SPECIFICATIONS

PASS SPEED	≤ 10 m/s
REPEATABILITY	≥ ±0.1mm
TEMPERATURE DRIFT	≤ 0.1mm
HYSTERESIS	≤ 1mm
OPERATING TEMPERATURE	-25°C to +70°C (-13°F to +158°F)
RATED OPERATIONAL VOLTAGE	10-30 VDC
RESIDUAL RIPPLE	≤ 10%
DC RATED OPERATIONAL CURRENT	≤ 200 mA
NO-LOAD CURRENT	≤ 15 mA
RESIDUAL CURRENT	≤ 0.1 mA
RATED INSULATION VOLTAGE	≤ 0.5 kV
SHORT-CIRCUIT PROTECTION	YES, CYCLIC
MAX. VOLTAGE DROP	≤ 1.8 V
WIRE BREAKAGE PROTECTION	INCORPORATED
REVERSE POLARITY PROTECTION	INCORPORATED
OUTPUT FUNCTION	NORMALLY OPEN, 3-WIRE, PNP
MAX. SWITCHING FREQUENCY	≤ 1.0 kHz
HOUSING MATERIAL	PLASTIC, PA12-GF30
ACTIVE FACE MATERIAL	PLASTIC, PA12-GF30
CABLE	∅4.0, PVC/GREY
VIBRATION	55 Hz, 1 mm AMPLITUDE (IN ALL 3 PLANES)
SHOCK	30 g, 11 ms
DEGREE OF PROTECTION	IP67
SWITCHING STATUS INDICATION	LED, YELLOW
INCLUDED IN SCOPE OF SUPPLY	CABLE CLIP

SOURCE DRAWING - FOR REFERENCE ONLY

NOTES:

- "W/KLP80" DESIGNATES MOUNTING BAND KLP-80 INCLUDED WITH SENSOR.
- FOR CYLINDERS WITH DIAMETER OF 8 TO 80 mm.

RELATED DOCUMENTS 1. 2. 3. 4.	3RD ANGLE PROJECTION 	THIS DRAWING IS CONFIDENTIAL AND THE PROPERTY OF TURCK INC. USE OF THIS DOCUMENT WITHOUT WRITTEN PERMISSION IS PROHIBITED.		3000 CAMPUS DRIVE MINNEAPOLIS, MN 55441 1-800-544-7769 (763) 553-7300 (763) 553-0708 fax www.turck.us	
	MATERIAL SEE SPECS	DRFT RDS APVD A.F.	DATE 01/18/13 SCALE 1=1.0	DESCRIPTION BIM-PST-AP6X 7M SPLICED W/KLP80	
FINISH	ALL DIMENSIONS DISPLAYED ON THIS DRAWING ARE FOR REFERENCE ONLY	UNIT OF MEASUREMENT <b>INCH [ MILLIMETER ]</b>		IDENTIFICATION NO. 4624092	REV D
D UPDATE DESCRIPTION	RDS 06/20/19	500000000158		DO NOT SCALE THIS DRAWING	
REV DESCRIPTION	BY	DATE	ECO NO.	FILE: 4624092	SHEET 1 OF 1