

# Magnetic Field Sensor for pneumatic cylinders (magnetic-field immune) BIM-NST-AP6X-0.6-RS4T/S34 W/O BKT

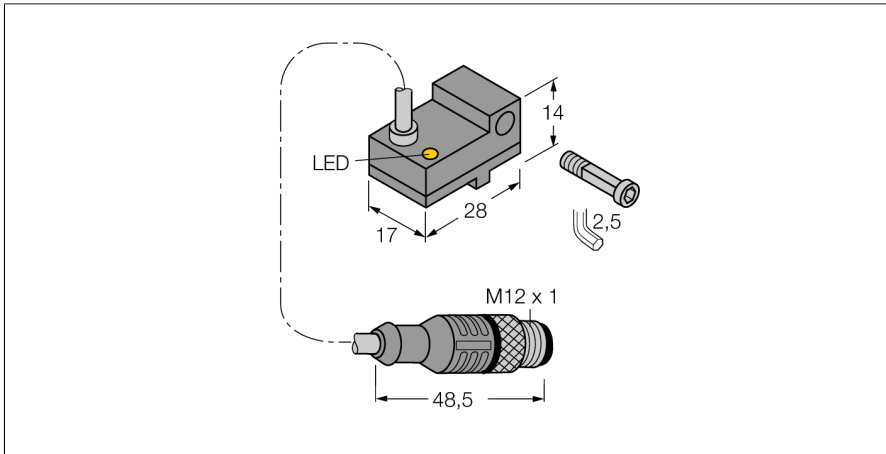

- Plastic, PA12-GF30
- Magnetic-inductive sensor
- Weld resistant to AC fields of 50...60 Hz
- DC 3-wire, 10...30 VDC
- NO contact, PNP output
- Pigtail with male end, M12 x 1

## Wiring Diagram

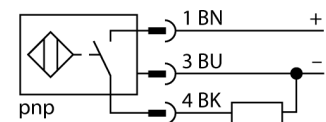

Type	BIM-NST-AP6X-0.6-RS4T/S34 W/O BKT
ID	4685688

Special version	S34 Corresponds to:Weld-field immune proximity sensors
-----------------	--

General data	
Pass speed	≤ 10 m/s
Repeatability	≤ ± 0.1 mm
Temperature drift	≤ 0.1 mm
Hysteresis	≤ 1 mm

Electrical data	
Operating voltage $U_s$	10...30 VDC
Ripple $U_{rs}$	≤ 10 % $U_{Bmax}$
DC rated operating current $I_s$	≤ 200 mA
Residual current	≤ 0.1 mA
Isolation test voltage	0.5 kV
Short-circuit protection	yes/Cyclic
Voltage drop at $I_s$	≤ 1.8 V
Wire break/reverse polarity protection	yes/Complete
Output function	3-wire, NO contact, PNP
Switching frequency	0.015 kHz

Mechanical data	
Design	Rectangular, NST
Dimensions	28 x 17 x 14 mm
Housing material	Plastic, PA12-GF30
Active area material	Plastic, PA12-GF30
Electrical connection	Cable with connector, M12 x 1
Cable quality	Ø 4mm, Gray, LiFYY, PVC, 0.6 m
Core cross-section	3 x 0.25 mm <sup>2</sup>

## Functional principle

Magnetic field sensors are activated by magnetic fields and are used, in particular, for the detection of the piston position in pneumatic cylinders. As magnetic fields can permeate non-magnetizable metals, they detect a permanent magnet attached to the piston through the aluminium cylinder wall.

Weld-field immune permapprox sensors "freeze" the switching status when detecting a magnetic AC field (50...60 Hz). In this way, false switching operations are prevented during the welding process. When the AC field disappears, the sensors resume standard operation.

Environmental conditions	
Ambient temperature	-25...+70 °C
Vibration resistance	55 Hz (1 mm)
Shock resistance	30 g (11 ms)
Protection class	IP67
MTTF	2283 years acc. to SN 29500 (Ed. 99) 40 °C

Mounting on the following profiles	
Cylindrical design	
Switching state	LED, Yellow
Included in delivery	1 x screw M3x20, 1 x tension bolt, 1 x spring washer

## Accessories

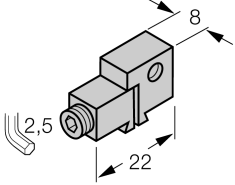
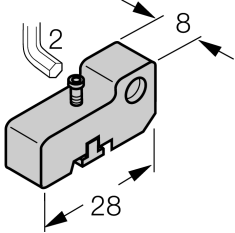
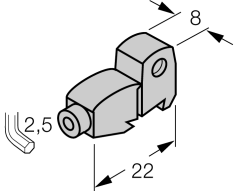
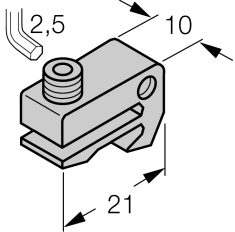
Type code	Ident-No.		Dimension drawing
KLN3	6970504	Mounting bracket for mounting magnetic field sensors on dovetail groove cylinders or  T-groove cylinders; clamping width: 5.2...13.5 mm; material: Anodized aluminum	
SMC-325	6970503	Mounting bracket for mounting magnetic field sensors on SMC cylinders; clamping width 4 mm; material: Anodized aluminum	
KLF1	6970401	Mounting bracket for mounting magnetic field sensors on profile cylinders with external dovetail guide; for all cylinder diameters, material: Anodized aluminum	
KLF2	6970402	Mounting bracket for mounting magnetic field sensors on profile cylinders (IMI Norgren); cylinder diameter: 32...100 mm; material: Anodized aluminum	
SMC-325	A3106	Mounting bracket for mounting magnetic field sensors on SMC cylinders; clamping width 4 mm; material: Anodized aluminum	