

BIM-IKE-AP6X-V1131 W/KLI3

Magnetic Field Sensor – For Pneumatic Cylinders

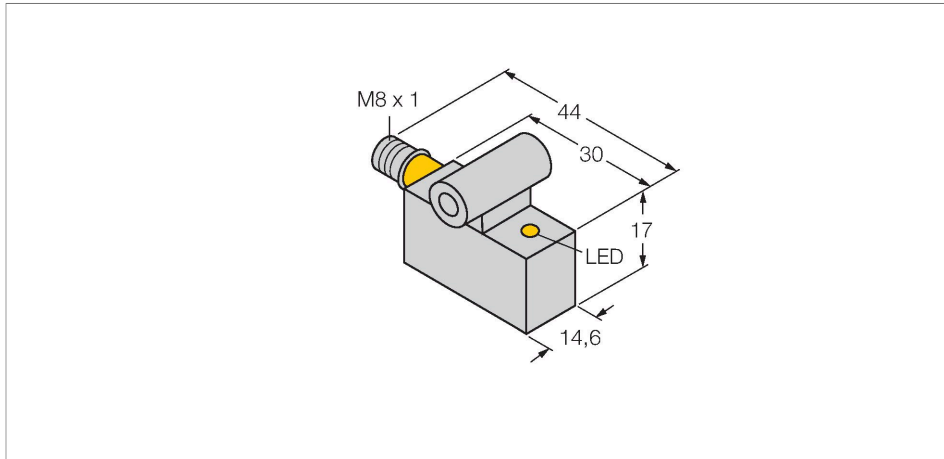

Features

- Rectangular, height 17 mm
- Active face in front
- Metal, GD-Zn
- Magnetic-inductive sensor
- DC 3-wire, 10...30 VDC
- NO contact, PNP output
- Male connector, M8 x 1

Wiring diagram

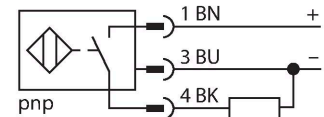

Technical data

Type	BIM-IKE-AP6X-V1131 W/KLI3
ID	4621695
General data	
Pass speed	≤ 10 m/s
Repeatability	≤ ± 0.1 mm
Temperature drift	≤ 0.1 mm
Hysteresis	≤ 1 mm
Electrical data	
Operating voltage U_b	10...30 VDC
Ripple U_{rs}	≤ 10 % U_{Bmax}
DC rated operating current I_b	≤ 200 mA
No-load current	≤ 15 mA
Residual current	≤ 0.1 mA
Isolation test voltage	0.5 kV
Short-circuit protection	yes/Cyclic
Voltage drop at I_b	≤ 1.8 V
Wire break/reverse polarity protection	yes/Complete
Output function	3-wire, NO contact, PNP
Switching frequency	1 kHz
Mechanical data	
Design	Rectangular, IKE
Dimensions	30 x 14.6 x 17 mm
Housing material	Metal, GD-Zn
Active area material	Plastic, PA12-GF30

Functional principle

Magnetic field sensors are activated by magnetic fields and are especially suited for piston position detection in pneumatic cylinders. Based on the fact that magnetic fields can permeate non-magnetizable metals, it is possible to detect a permanent magnet attached to the piston through the aluminium wall of the cylinder.

Technical data

Electrical connection	Connector, M8 × 1
Environmental conditions	
Ambient temperature	-25...+70 °C
Vibration resistance	55 Hz (1 mm)
Shock resistance	30 g (11 ms)
Protection class	IP67
MTTF	2283 years acc. to SN 29500 (Ed. 99) 40 °C
Mounting on the following profiles	
Cylindrical design	○ ##
Switching state	LED, Yellow
Included in delivery	KLI3

Mounting instructions

Mounting instructions/Description

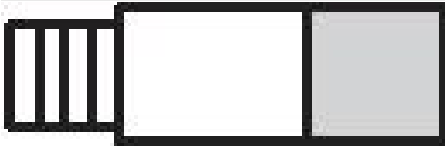

Accessories

KLI5Z

6971803

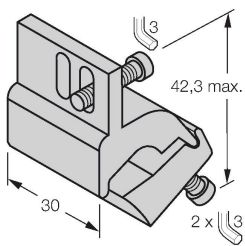

Mounting bracket for mounting magnetic field sensors on tie-rod cylinders; cylinder diameter: 32...63 mm; material: Aluminum

KLI6Z

6971806

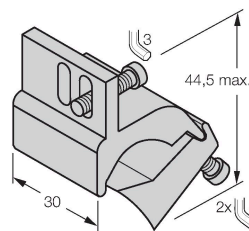

Mounting bracket for mounting magnetic field sensors on tie-rod cylinders; cylinder diameter: 50...125 mm; material: Aluminum

KLI6

6971805

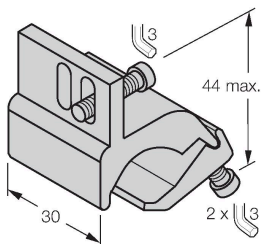

Mounting bracket for mounting magnetic field sensors on profile cylinders; cylinder diameter: 50...100 mm; material: Aluminum

KLI7

6971810

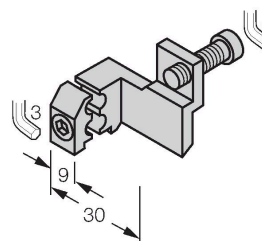

Mounting bracket for mounting magnetic field sensors on profile cylinders with external dovetail guide; cylinder diameter: 32...200 mm; material: Aluminum

KLI1

69710

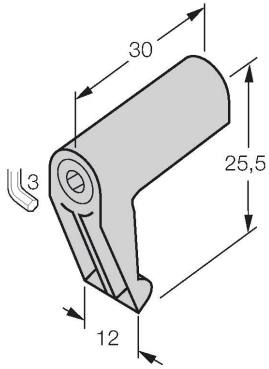

Mounting bracket for mounting magnetic field sensors on tie-rod cylinders; cylinder diameter: 32...100 mm; material: Die-cast Zinc

KLI5

6971802

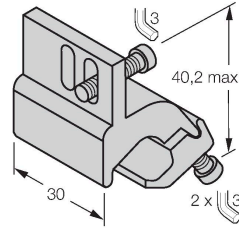

Mounting bracket for mounting magnetic field sensors on profile cylinders; cylinder diameter: 32...50 mm; material: Aluminum

KLI3

69712

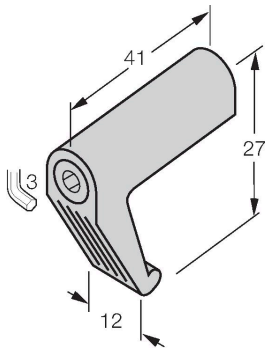

Mounting bracket for mounting magnetic field sensors on tie-rod cylinders; cylinder diameter: 63...160 mm; material: Die-cast Zinc