

WIRING DIAGRAM

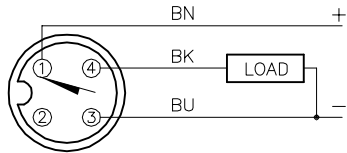

OUTPUT: AP6X2

SHORT-CIRCUIT AND OVERLOAD PROTECTED

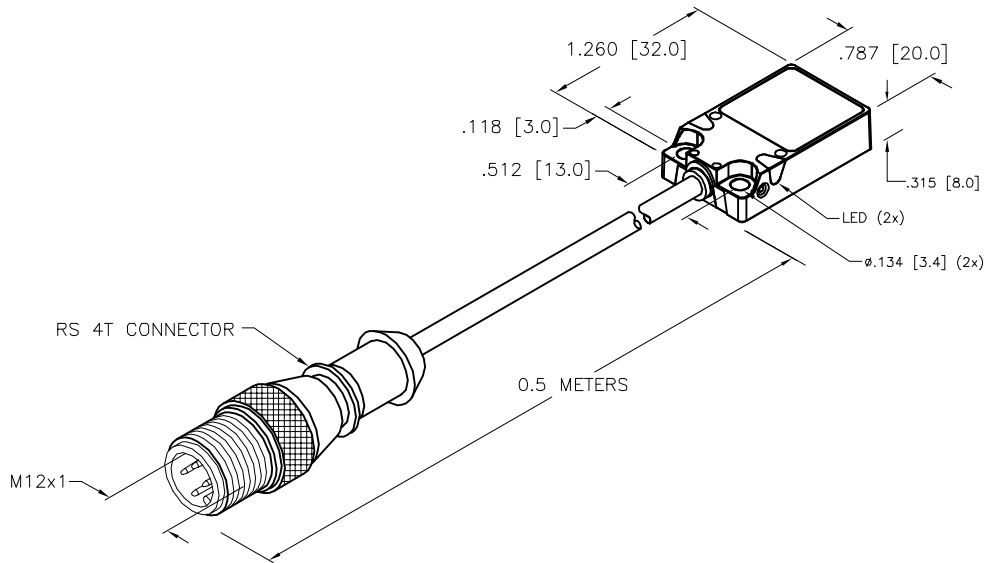

SPECIFICATIONS

RATED OPERATING DISTANCE	8mm = .315" (NOMINAL)
MOUNTING MODE	FLUSH
TEMPERATURE DRIFT	$\leq \pm 10\%$ $\leq \pm 15\%$, $\leq 25^\circ\text{C}$ v $\geq +70^\circ\text{C}$
HYSTERESIS	3-15%
MIN. REPEAT ACCURACY	$\leq 2\%$
OPERATING TEMPERATURE	-25°C TO $+70^\circ\text{C}$ (-13°F + 158°F)
RATED OPERATIONAL VOLTAGE	10-30 VDC
RESIDUAL RIPPLE	$\leq 10\%$
DC RATED OPERATIONAL CURRENT	≤ 200 mA
NO-LOAD CURRENT	≤ 15 mA
RESIDUAL CURRENT	≤ 0.1 mA
RATED INSULATION VOLTAGE	≤ 0.5 kV
SHORT-CIRCUIT PROTECTED	YES
MAX. VOLTAGE DROP	≤ 1.8 V
REVERSE POLARITY PROTECTION	INCORPORATED
WIRE-BREAK PROTECTION	INCORPORATED
OUTPUT FUNCTION	NORMALLY OPEN, 3-WIRE, PNP
MAX. SWITCHING FREQUENCY	≤ 0.25 kHz
HOUSING MATERIAL	METAL, ZAMAK, NICKEL-PLATED
ACTIVE FACE MATERIAL	PLASTIC, PP, YELLOW
CABLE DIAMETER/MATERIAL	$\phi 3\text{mm}$, LifY-11Y, TPU
SHOCK	30 g, 11 ms
VIBRATION	55 Hz, 1 mm AMPLITUDE (IN ALL 3 PLANES)
DEGREE OF PROTECTION	IP68 (SENSOR) IP67 (CONNECTOR)
OPERATING VOLTAGE DISPLAY	LED: GREEN
SWITCHING STATUS INDICATION	LED: YELLOW

SOURCE DRAWING - FOR REFERENCE ONLY

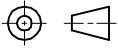
RELATED DOCUMENTS		3RD ANGLE PROJECTION		THIS DRAWING IS CONFIDENTIAL AND THE PROPERTY OF TURCK INC. USE OF THIS DOCUMENT WITHOUT WRITTEN PERMISSION IS PROHIBITED.		 3000 CAMPUS DRIVE MINNEAPOLIS, MN 55441 1-800-544-7769 (763) 553-7300 (763) 553-0708 fax www.turck.us	
1.			DRFT	RDS	DATE	04/02/14	DESCRIPTION B18U-Q08-AP6X2-0.5-RS4T
2.			APVD	K.H.	SCALE	1=1.3	
3.		ALL DIMENSIONS DISPLAYED ON THIS DRAWING ARE FOR REFERENCE ONLY CONTACT TURCK FOR MORE INFORMATION	UNIT OF MEASUREMENT		IDENTIFICATION NO.		REV
4.			INCH [MILLIMETER]		16620068		E
MATERIAL		SEE NOTES		DO NOT SCALE THIS DRAWING		FILE: 16620068	
FINISH		SEE NOTES		SHEET 1 OF 1			

E	UPDATE SPECS AND SENSOR BODY	RDS	03/12/21	76563
REV	DESCRIPTION	BY	DATE	ECO NO.