

# BI8-Q10-VP6X2-0.2-RS4.4T

## Inductive Sensor

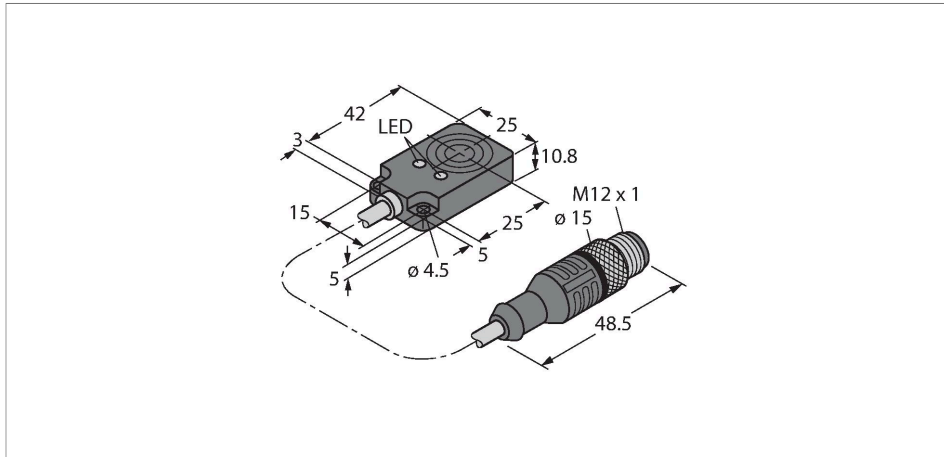

### Technical data

Type	BI8-Q10-VP6X2-0.2-RS4.4T
ID	1662097
<b>General data</b>	
Rated switching distance	8 mm
Mounting conditions	Flush
Secured operating distance	$\leq (0.81 \times S_n)$ mm
Correction factors	St37 = 1; Al = 0.3; stainless steel = 0.7; Ms = 0.4
Repeat accuracy	$\leq 2\%$ of full scale
Hysteresis	3...15 %
<b>Electrical data</b>	
Operating voltage $U_B$	10...30 VDC
Ripple $U_{ss}$	$\leq 10\%$ $U_{Bmax}$
DC rated operating current $I_e$	$\leq 200$ mA
No-load current	$\leq 15$ mA
Residual current	$\leq 0.1$ mA
Isolation test voltage	0.5 kV
Short-circuit protection	yes/Cyclic
Voltage drop at $I_e$	$\leq 1.8$ V
Wire break/reverse polarity protection	yes/Complete
Output function	4-wire, Complementary contact, PNP
Switching frequency	1 kHz
<b>Mechanical data</b>	
Design	Rectangular, Q10



### Features

- Rectangular, height 10.8 mm
- Active face on top
- Plastic, PBT-GF30-V0
- DC 4-wire, 10...30 VDC
- Changeover contact, PNP output
- Cable with male end M12 x 1

### Wiring diagram

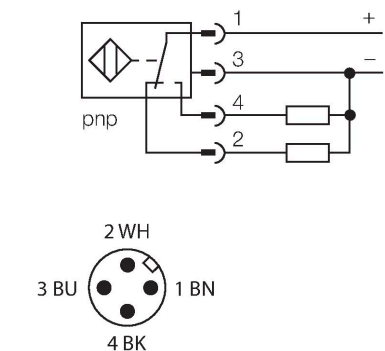

### Functional principle

Inductive sensors detect metal objects contactless and wear-free. For this, they use a high-frequency electromagnetic AC field that interacts with the target. Inductive sensors generate this field via an RLC circuit with a ferrite coil.

## Technical data

Dimensions	42 x 25 x 10.8 mm
Housing material	Plastic, PBT-GF30-V0
Active area material	PBT-GF30-V0
Material coupling nut	metal, CuZn, nickel-plated
Electrical connection	Cable with connector, M12 × 1
Cable quality	Ø 4 mm, LiFY-11Y, PUR, 0.2 m
Core cross-section	4 x 0.25 mm <sup>2</sup>
<b>Environmental conditions</b>	
Ambient temperature	-25...+70 °C
Vibration resistance	55 Hz (1 mm)
Shock resistance	30 g (11 ms)
Protection class	IP67
MTTF	2283 years acc. to SN 29500 (Ed. 99) 40 °C
Power-on indication	LED, Green
Switching state	LED, Yellow

## Mounting instructions

Mounting instructions/Description		
	Distance D	2 x B
	Distance W	3 x Sn
	Distance S	1 x B
	Distance G	6 x Sn
	Width active area B	25 mm

B18-Q10-VP6X2-0.2-RS4.4T| 06/30/2025 09-55 | technical changes reserved