

WIRING DIAGRAM

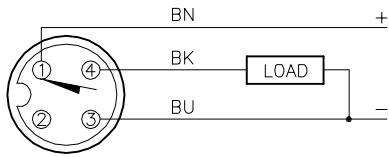

OUTPUT: AP6X2

SHORT-CIRCUIT AND OVERLOAD PROTECTED

SPECIFICATIONS

RATED OPERATING DISTANCE	7mm = .276" (NOMINAL)
MOUNTING MODE	FLUSH
TEMPERATURE DRIFT	≤ ± 10%
HYSTERESIS (SWITCHING DISTANCE)	3-15%
MIN. REPEAT ACCURACY	≤ 2%
OPERATING TEMPERATURE	-25°C to +70°C (-13°F to +158°F)
RATED OPERATIONAL VOLTAGE	10-30 VDC
MAX. RIPPLE	≤ 10%
RATED OPERATIONAL CURRENT	≤ 200 mA
NO-LOAD CURRENT	≤ 15 mA
RESIDUAL CURRENT	≤ 0.1 mA
RATED INSULATION VOLTAGE	≤ 0.5 kV
SHORT-CIRCUIT PROTECTED	YES
MAX. VOLTAGE DROP	≤ 1.8 V
REVERSE POLARITY PROTECTION	INCORPORATED
WIRE-BREAK PROTECTION	INCORPORATED
OUTPUT FUNCTION	NORMALLY OPEN, 3-WIRE, pnp
MAX. SWITCHING FREQUENCY	≤ 0.5 kHz
HOUSING MATERIAL	METAL, ZAMAK, NICKEL-PLATED
ACTIVE FACE	PLASTIC, PP, YELLOW
CABLE	∅3mm, LiY-11Y, TPU
SHOCK	30 g, 11 ms
VIBRATION	55 Hz, 1 mm AMPLITUDE (IN ALL 3 PLANES)
DEGREE OF PROTECTION	IP68
OPERATING VOLTAGE DISPLAY	LED: GREEN
SWITCHING STATUS INDICATION	LED: YELLOW

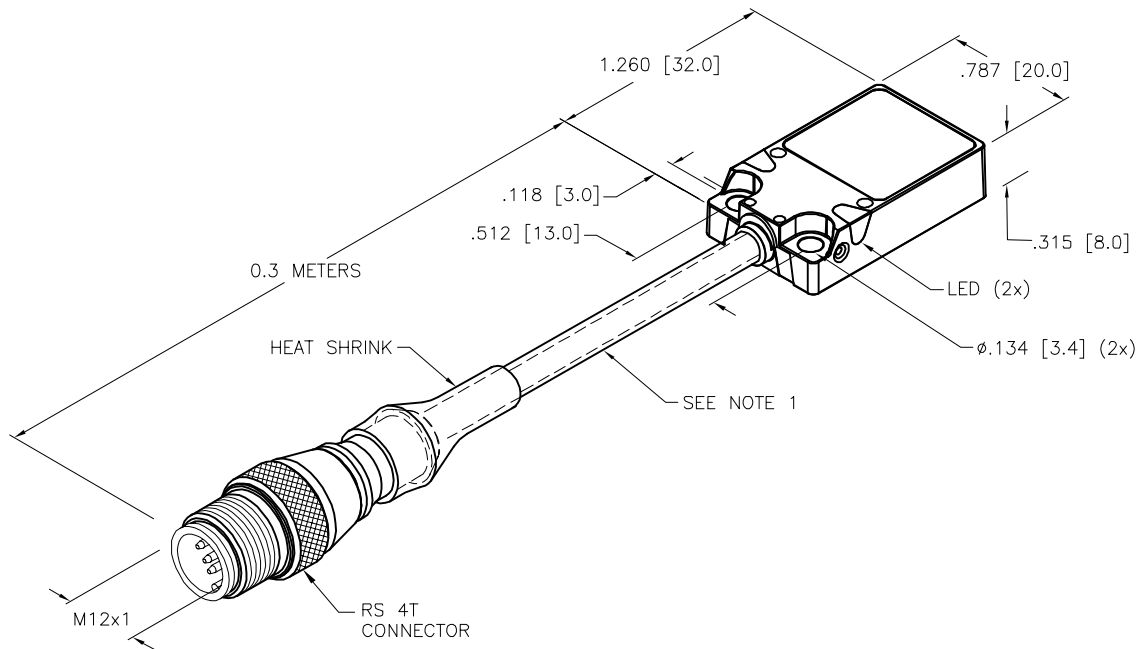

SOURCE DRAWING - FOR REFERENCE ONLY

NOTES:

1. "/S1154" DESIGNATES WELDGUARD COATED SENSOR TO BE USED AS BASE UNIT. USE PTFE TUBING OVER SENSOR CABLE.

- PTFE TUBING STARTS AT SENSOR END, AND GETS CAPTURED IN THE CONNECTOR MOLDING MATERIAL

- SLIDE 35MM OF SHRINK TUBING TO OVERLAP CONNECTOR MOLD BODY AND PTFE TUBING

RELATED DOCUMENTS		3RD ANGLE PROJECTION		THIS DRAWING IS CONFIDENTIAL AND THE PROPERTY OF TURCK INC. USE OF THIS DOCUMENT WITHOUT WRITTEN PERMISSION IS PROHIBITED.				3000 CAMPUS DRIVE MINNEAPOLIS, MN 55441 1-800-544-7769 (763) 553-7300 (763) 553-0708 fax www.turck.us	
1. 2. 3. 4.				DRFT NF		DATE 11/12/15		DESCRIPTION	
MATERIAL		ALL DIMENSIONS DISPLAYED ON THIS DRAWING ARE FOR REFERENCE ONLY		APVD A.F.		SCALE 1=1.0		BI7-Q08-AP6X2-0.3-RS4T/S1154	
FINISH		CONTACT TURCK FOR MORE INFORMATION		UNIT OF MEASUREMENT		IDENTIFICATION NO.		REV	
				INCH [ MILLIMETER ]		16016006		C	
C UPDATE SPECS AND SENSOR BODY		RDS 03/12/21		76565		DO NOT SCALE THIS DRAWING		FILE: 16016006	
REV DESCRIPTION		BY DATE		ECO NO.		SHEET 1 OF 1			