

WIRING DIAGRAM

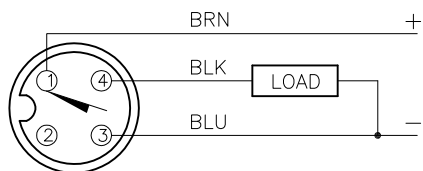

OUTPUT: AP6X

SHORT-CIRCUIT AND OVERLOAD PROTECTED

LOCKNUT LN-MT12

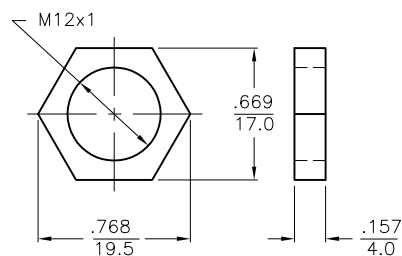

SPECIFICATIONS

RATED OPERATING DISTANCE	6mm =.236"
MOUNTING MODE	FLUSH
MIN. REPEAT ACCURACY	≤ 2%
TEMPERATURE DRIFT	≤ ±10%
HYSTERESIS	3-15%
OPERATING TEMPERATURE	-25°C to +70°C (-13°F to +158°F)
RATED OPERATIONAL VOLTAGE	10-30 VDC
RESIDUAL RIPPLE	≤ 10%
RATED OPERATIONAL CURRENT	≤ 200 mA
NO-LOAD CURRENT	≤ 15 mA
RESIDUAL CURRENT	≤ 0.1 mA
RATED INSULATION VOLTAGE	≤ 0.5 kV
SHORT-CIRCUIT PROTECTED	YES
MAX. VOLTAGE DROP	≤ 1.8 V
REVERSE POLARITY PROTECTION	INCORPORATED
WIRE-BREAK PROTECTION	INCORPORATED
OUTPUT FUNCTION	NORMALLY OPEN, 3-WIRE, PNP
MAX. SWITCHING FREQUENCY	≤ 2 kHz
HOUSING MATERIAL	METAL, BRASS/PTFE-COATED
ACTIVE FACE	PLASTIC, LCP-GF30
CONNECTION	M12x1
SHOCK RESISTANCE	30 g, 11 ms
VIBRATION RESISTANCE	55 Hz, 1 mm AMPLITUDE (IN ALL 3 PLANES)
DEGREE OF PROTECTION	IP68
SWITCHING STATUS INDICATION	LED: YELLOW

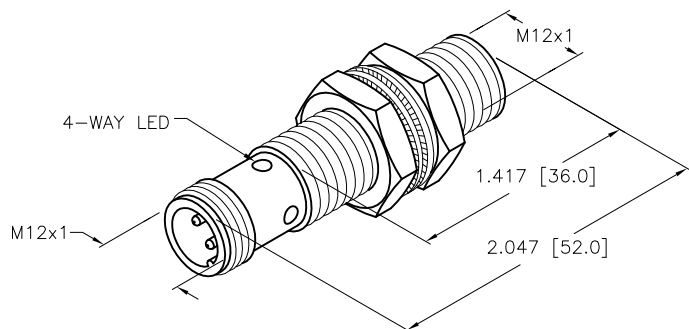

SOURCE DRAWING - FOR REFERENCE ONLY

NOTES:

1. UPROX HAS WELD FIELD IMMUNITY, SENSOR IS SUITABLE FOR USE ON RESISTANCE MACHINES.
2. "/S1589" DESIGNATES WELDGUARD FRONT FACE.

RELATED DOCUMENTS 1. 2. 3. 4.	3RD ANGLE PROJECTION 	THIS DRAWING IS CONFIDENTIAL AND THE PROPERTY OF TURCK INC. USE OF THIS DOCUMENT WITHOUT WRITTEN PERMISSION IS PROHIBITED.		3000 CAMPUS DRIVE MINNEAPOLIS, MN 55441 1-800-544-7769 (763) 553-7300 (763) 553-0708 fax www.turck.us	
	MATERIAL	DRFT RDS	DATE 09/10/15	DESCRIPTION BI6U-MT12-AP6X-H1141/S1589	
FINISH	ALL DIMENSIONS DISPLAYED ON THIS DRAWING ARE FOR REFERENCE ONLY	APVD A.F.	SCALE 1=1.0	IDENTIFICATION NO. 16448110	
CONTACT TURCK FOR MORE INFORMATION		UNIT OF MEASUREMENT INCH [MILLIMETER]		REV B	
DO NOT SCALE THIS DRAWING		FILE: 16448110		SHEET 1 OF 1	

B	UPDATE ID NUMBER PER HARMONIZATION PROJECT	CBM	12/21/17	
REV	DESCRIPTION	BY	DATE	ECO NO.