

# BI6-EGT12FE-AP6X-H1141/S1589

## Inductive Sensor – Stainless Steel Front

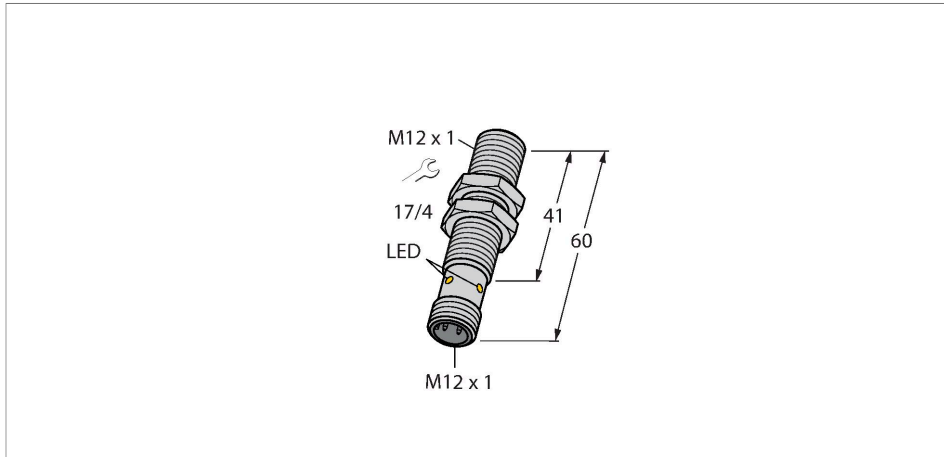

### Features

- Threaded barrel, M12 x 1
- Stainless steel, 1.4305
- PTFE-coated
- DC 3-wire, 10...30 VDC
- NO contact, PNP output
- M12 x 1 male connector

### Wiring diagram

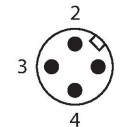

### Technical data

Type	BI6-EGT12FE-AP6X-H1141/S1589
ID	46147061
Special version	S1589 Corresponds to: With weldguard coating
<b>General data</b>	
Rated switching distance	6 mm
Mounting conditions	Flush
Secured operating distance	$\leq (0.81 \times S_n)$ mm
Correction factors	St37 = 1; Al = 0.3; stainless steel = 0.7; Ms = 0.4
Repeat accuracy	$\leq 5\%$ of full scale
Hysteresis	3 %
<b>Electrical data</b>	
Operating voltage $U_b$	10...30 VDC
Ripple $U_{ss}$	$\leq 20\%$ $U_{Bmax}$
DC rated operating current $I_b$	$\leq 200$ mA
No-load current	$\leq 10$ mA
Residual current	$\leq 0.1$ mA
Isolation test voltage	0.5 kV
Short-circuit protection	yes/Cyclic
Voltage drop at $I_b$	$\leq 2$ V
Wire break/reverse polarity protection	yes/Complete
Output function	3-wire, NO contact, PNP
Switching frequency	0.6 kHz

### Functional principle

The inductive all-metal switches operate on the basis of the electromagnetic pulse method. Unlike standard inductive sensors, the magnetic field is not generated through oscillation but through short, periodic current pulses flowing through the coil. The magnetic field induces voltage in the object to be detected, which, for its part creates a current flow in this object. After switching off the current pulse, the current in the object also drops, now inducing voltage back in the emitter coil. This voltage is the wanted signal and remains unaffected by energy dissipation in the magnetic field. Only non-ferromagnetic or poorly conductive metals provide a low signal.

## Technical data

Mechanical data	
Design	Threaded barrel, M12 x 1
Dimensions	60 mm
Housing material	Stainless steel, 1.4305 (AISI 303)
Active area material	Stainless steel, 1.4305 (AISI 303), PTFE-coated
Admissible pressure on front cap	≤ 80 bar
Max. tightening torque of housing nut	20 Nm
Electrical connection	Connector, M12 × 1
Environmental conditions	
Ambient temperature	-25...+70 °C
Vibration resistance	55 Hz (1 mm)
Shock resistance	30 g (11 ms)
Protection class	IP68 IP69K
MTTF	336 years acc. to SN 29500 (Ed. 99) 20 °C
Switching state	LED, Yellow, LED flashing: 0.8 s, < s ≤ s,

## Mounting instructions

### Mounting instructions/Description

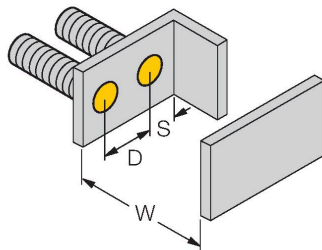

Distance D 40 mm

Distance W 18 mm

Distance T 36 mm

Distance S 12 mm

Distance G 36 mm

Diameter active area B  $\varnothing$  12 mm

The following reduction factors apply when flush-mounted in:

Steel: 0.7

Aluminium: 1.15

Brass: 1.05

Stainless steel: 0.8

## Accessories

MW12

6945003

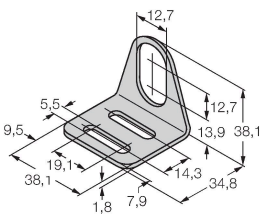

Mounting bracket for threaded barrel sensors; material: Stainless steel A2 1.4301 (AISI 304)

BSS-12

6901321

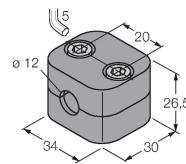

Mounting clamp for smooth and threaded barrel sensors; material: Polypropylene