

WIRING DIAGRAM

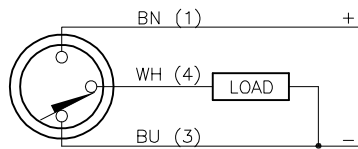

OUTPUT: RP6

SHORT-CIRCUIT AND OVERLOAD PROTECTED

SPECIFICATIONS

RATED OPERATING DISTANCE	5mm = .197"
MOUNTING MODE	FLUSH
TEMPERATURE DRIFT	≤ ±10%
HYSTERESIS	3-15%
MIN. REPEAT ACCURACY	≤ 2%
OPERATING TEMPERATURE	-25°C to +70°C (-13°F to +158°F)
RATED OPERATIONAL VOLTAGE	10-30 VDC
RESIDUAL RIPPLE	≤ 10%
DC RATED OPERATIONAL CURRENT	≤ 200 mA
NO-LOAD CURRENT	≤ 15 mA
RESIDUAL CURRENT	≤ 0.1 mA
RATED INSULATION VOLTAGE	≤ 0.5 kV
SHORT-CIRCUIT PROTECTED	YES
MAX. VOLTAGE DROP	≤ 1.8 V
REVERSE POLARITY PROTECTION	INCORPORATED
WIRE-BREAK PROTECTION	INCORPORATED
OUTPUT FUNCTION	3-WIRE, DC, NORMALLY CLOSED, PNP
MAX. SWITCHING FREQUENCY	≤ 0.5 kHz
HOUSING MATERIAL	METAL, ZAMAK, NICKEL-PLATED
ACTIVE FACE	PLASTIC, PP, YELLOW
CABLE	∅3mm, LiFy-11Y, TPU
SHOCK	30 g, 11 ms
VIBRATION	55 Hz, 1 mm AMPLITUDE (IN ALL 3 PLANES)
DEGREE OF PROTECTION	IP68
OPERATING VOLTAGE DISPLAY	LED: GREEN
SWITCHING STATUS INDICATION	LED: YELLOW

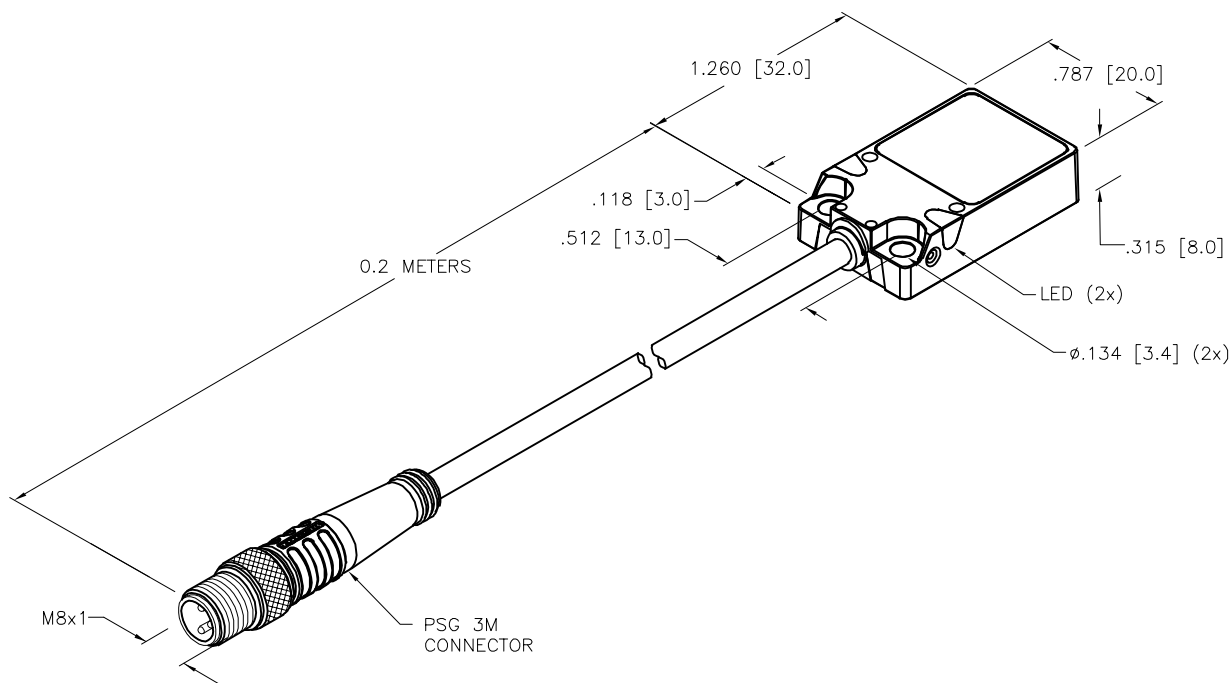

CABLE LENGTH	TOLERANCE*
ALL LENGTHS	+ 4% (OR 50mm) OF LENGTH - 0% (OR 0mm) OF LENGTH WHICHEVER IS GREATER
STRIP LENGTH	TOLERANCE*
0-7mm	±0.5mm
8-29mm	±1.0mm
30-49mm	±2.0mm
50-69mm	±3.0mm
70-100mm	±4.0mm
OVER 100mm	±5.0mm

\* UNLESS OTHERWISE SPECIFIED

NOTES:

1. "/S567" DESIGNATES SENSOR WIRED NORMALLY CLOSED.

SOURCE DRAWING - FOR REFERENCE ONLY

RELATED DOCUMENTS 1. 2. 3. 4.	3RD ANGLE PROJECTION 	THIS DRAWING IS CONFIDENTIAL AND THE PROPERTY OF TURCK INC. USE OF THIS DOCUMENT WITHOUT WRITTEN PERMISSION IS PROHIBITED.		3000 CAMPUS DRIVE MINNEAPOLIS, MN 55441 1-800-544-7769 (763) 553-7300 (763) 553-0708 fax www.turck.us	
	MATERIAL	DRFT KB APVD A.F.	DATE 06/24/24 SCALE 1=1.0	DESCRIPTION B15-Q08-VP6X2-0.2-PSG3M/S567	
FINISH	ALL DIMENSIONS DISPLAYED ON THIS DRAWING ARE FOR REFERENCE ONLY  CONTACT TURCK FOR MORE INFORMATION	UNIT OF MEASUREMENT <b>INCH [ MILLIMETER ]</b>		IDENTIFICATION NO. 200011655	REV A
DO NOT SCALE THIS DRAWING		FILE: 200011655			SHEET 1 OF 1



A	DRAWING RELEASE	AS	06/27/24	
REV	DESCRIPTION	BY	DATE	ECO NO.