

# BI3U-MT12E-AN6X2-H1141/S1589

## Inductive Sensor – With WeldGuard™ coating

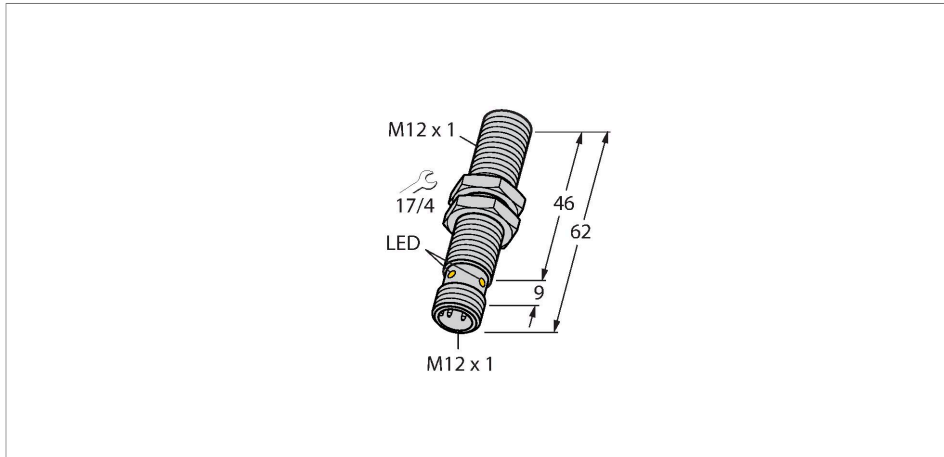

### Features

- Threaded barrel, M12 x 1
- Brass, PTFE-coated
- Factor 1 for all metals
- Protection class IP68
- Resistant to magnetic fields
- Extended temperature range
- High switching frequency
- DC 3-wire, 10...30 VDC
- NO contact, NPN output
- M12 x 1 male connector

### Wiring diagram

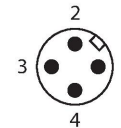
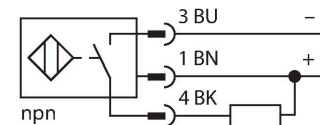

### Technical data

Type	BI3U-MT12E-AN6X2-H1141/S1589
ID	1634290
Special version	S1589 Corresponds to: With weldguard coating
<b>General data</b>	
Rated switching distance	3 mm
Mounting conditions	Flush
Secured operating distance	≤ (0.81 × S <sub>n</sub> ) mm
Repeat accuracy	≤ 2 % of full scale
	≤ ± 15 %, ≤ -25 °C v ≥ +70 °C
Hysteresis	3...15 %
<b>Electrical data</b>	
Operating voltage U <sub>B</sub>	10...30 VDC
Ripple U <sub>ss</sub>	≤ 10 % U <sub>Bmax</sub>
DC rated operating current I <sub>B</sub>	≤ 200 mA
No-load current	≤ 25 mA
Residual current	≤ 0.1 mA
Isolation test voltage	0.5 kV
Short-circuit protection	yes/Cyclic
Voltage drop at I <sub>B</sub>	≤ 1.8 V
Wire break/reverse polarity protection	yes/Complete
Output function	3-wire, NO contact, NPN
DC field stability	300 mT
AC field stability	300 mT <sub>SS</sub>

### Functional principle

Inductive sensors are designed for wear-free and contactless detection of metal objects. approx Factor 1 sensors have significant advantages due to their patented ferrite-coreless 3-coil system. They detect all metals at the same large switching distance and are resistant to magnetic fields. Turck WeldGuard sensors for use in welding systems are equipped with a thin coating made of thermosetting plastic. This high-tech coating is resistant to abrasion and withstands mechanical stress.

## Technical data

Switching frequency	3 kHz
<b>Mechanical data</b>	
Design	Threaded barrel, M12 x 1
Dimensions	62 mm
Housing material	Metal, CuZn, PTFE-coated
Active area material	Plastic, LCP + WeldGuard™, PTFE-coated
End cap	Plastic, EPTR
Max. tightening torque of housing nut	7 Nm
Electrical connection	Connector, M12 × 1
<b>Environmental conditions</b>	
Ambient temperature	-30...+85 °C
Vibration resistance	55 Hz (1 mm)
Shock resistance	30 g (11 ms)
Protection class	IP68
MTTF	874 years acc. to SN 29500 (Ed. 99) 40 °C
Power-on indication	LED, Green
Switching state	LED, Yellow

## Mounting instructions

### Mounting instructions/Description



Distance D	24 mm
Distance W	3 x Sn
Distance T	3 x B
Distance S	1.5 x B
Distance G	6 x Sn
Diameter active area B	Ø 12 mm

## Accessories

BST-12B

6947212

Mounting clamp for threaded barrel sensors, with dead-stop; material: PA6



QMT-12

6945106

Quick-mount bracket with dead-stop; material: brass, PTFE-coated; Male thread M16 x 1. Note: The switching distance of the proximity switches may change when using quick-mount brackets.



BSS-12

6901321

Mounting clamp for smooth and threaded barrel sensors; material: Polypropylene

