

BI3-MT12-AD4X-0.3-RS4.23T/S1589

Inductive Sensor

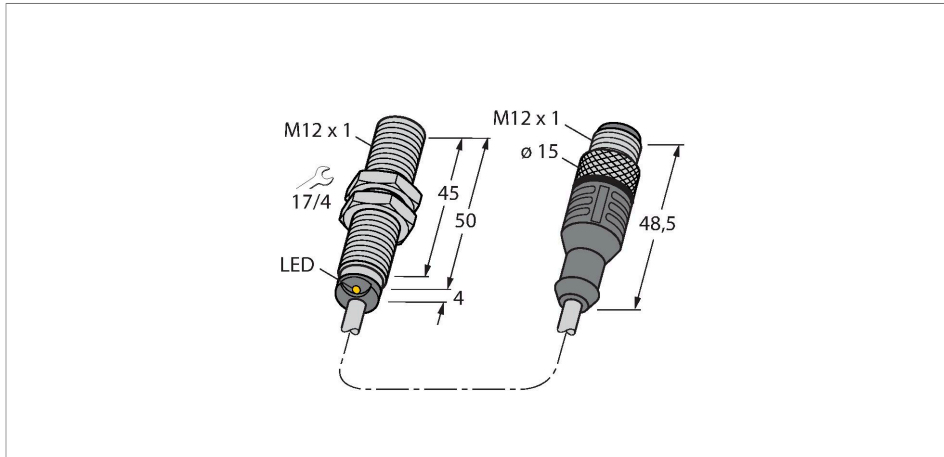

Features

- Threaded barrel, M12 x 1
- Brass, PTFE-coated
- DC 2-wire, 10...65 VDC
- NO contact
- Pigtail with M12 x 1 connector

Technical data

Type	BI3-MT12-AD4X-0.3-RS4.23T/S1589
ID	44050820
Special version	S1589 Corresponds to: With weldguard coating

General data	
Rated switching distance	3 mm
Mounting conditions	Flush
Secured operating distance	$\leq (0.81 \times S_n)$ mm
Correction factors	St37 = 1; Al = 0.3; stainless steel = 0.7; Ms = 0.4
Repeat accuracy	≤ 2 % of full scale
Temperature drift	$\leq \pm 10$ %
Hysteresis	1...15 %

Electrical data	
Operating voltage U_B	10...65 VDC
Ripple U_{ss}	≤ 10 % U_{Bmax}
DC rated operating current I_o	≤ 100 mA
Residual current	≤ 0.6 mA
Isolation test voltage	0.5 kV
Short-circuit protection	yes/Cyclic
Voltage drop at I_o	≤ 5 V
Wire break/reverse polarity protection	Complete
Output function	2-wire, NO contact, 2-wire
Smallest operating current	≥ 3 mA
Switching frequency	1 kHz

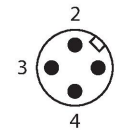
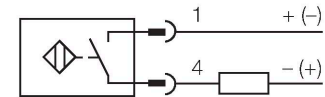

Functional principle

Inductive sensors detect metal objects contactless and wear-free. For this, they use a high-frequency electromagnetic AC field that interacts with the target. Inductive sensors generate this field via an RLC circuit with a ferrite coil.

Technical data

Mechanical data	
Design	Threaded barrel, M12 x 1
Dimensions	54 mm
Housing material	Metal, CuZn, PTFE-coated
Active area material	Plastic, PA12-GF30, PTFE-coated
End cap	Plastic, EPTR
Material coupling nut	metal, CuZn, nickel-plated
Max. tightening torque of housing nut	7 Nm
Electrical connection	Cable with connector, M12 × 1
Cable quality	Ø 5.2 mm, LifYY, PVC, 0.3 m
Core cross-section	2 x 0.34 mm ²
Environmental conditions	
Ambient temperature	-25...+70 °C
Vibration resistance	55 Hz (1 mm)
Shock resistance	30 g (11 ms)
Protection class	IP67
MTTF	2283 years acc. to SN 29500 (Ed. 99) 40 °C
Switching state	LED, Yellow

Mounting instructions

Mounting instructions/Description



Distance D	24 mm
Distance W	9 mm
Distance T	36 mm
Distance S	18 mm
Distance G	18 mm
Diameter active area B	Ø 12 mm

Accessories

BST-12B

6947212

Mounting clamp for threaded barrel sensors, with dead-stop; material: PA6



QMT-12

6945106

Quick-mount bracket with dead-stop; material: brass, PTFE-coated; Male thread M16 × 1. Note: The switching distance of the proximity switches may change when using quick-mount brackets.



BSS-12

6901321

Mounting clamp for smooth and threaded barrel sensors; material: Polypropylene

