

# BI3-EG08FE-AP6X-0.3-RS4T

## Inductive Sensor – Stainless Steel Front

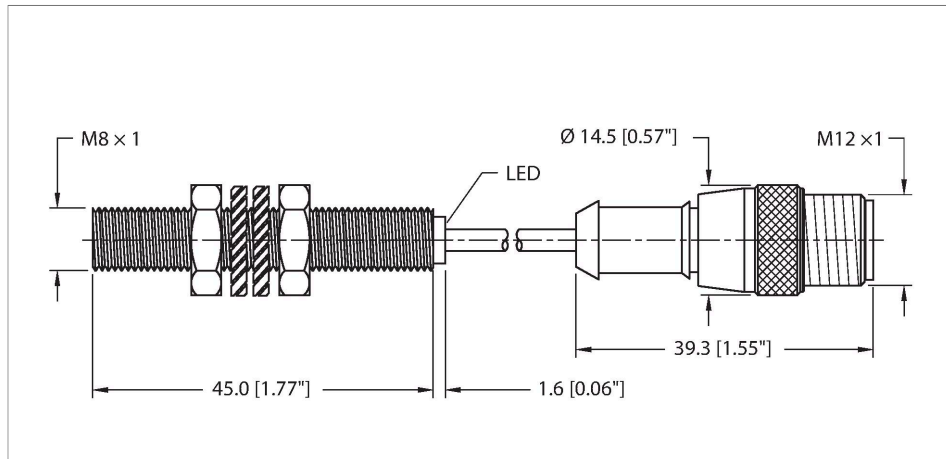

### Features

- Threaded barrel, M8 x 1
- Stainless steel, 1.4305
- DC 3-wire, 10...30 VDC
- NO contact, PNP output
- Pigtail with male end M12 x 1

### Wiring diagram



### Technical data

Type	BI3-EG08FE-AP6X-0.3-RS4T
ID	46147041
<b>General data</b>	
Rated switching distance	3 mm
Mounting conditions	Flush
Secured operating distance	$\leq (0.81 \times S_n)$ mm
Correction factors	St37 = 1; Al = 0.3; stainless steel = 0.7; Ms = 0.4
Repeat accuracy	$\leq 5$ % of full scale
Hysteresis	20 %
<b>Electrical data</b>	
Operating voltage $U_B$	10...30 VDC
Ripple $U_{rs}$	$\leq 20$ % $U_{Bmax}$
DC rated operating current $I_o$	$\leq 200$ mA
No-load current	$\leq 10$ mA
Residual current	$\leq 0.1$ mA
Isolation test voltage	0.5 kV
Short-circuit protection	yes/Cyclic
Voltage drop at $I_o$	$\leq 2$ V
Wire break/reverse polarity protection	yes/Complete
Output function	3-wire, NO contact, PNP
Switching frequency	1 kHz
<b>Mechanical data</b>	
Design	Threaded barrel, M8 x 1

### Functional principle

The inductive all-metal switches operate on the basis of the electromagnetic pulse method. Unlike standard inductive sensors, the magnetic field is not generated through oscillation but through short, periodic current pulses flowing through the coil. The magnetic field induces voltage in the object to be detected, which, for its part creates a current flow in this object. After switching off the current pulse, the current in the object also drops, now inducing voltage back in the emitter coil. This voltage is the wanted signal and remains unaffected by energy dissipation in the magnetic field. Only non-ferromagnetic or poorly conductive metals provide a low signal.

## Technical data

Dimensions	45 mm
Housing material	Stainless steel, 1.4305 (AISI 303)
Active area material	Stainless steel, 1.4305 (AISI 303)
Admissible pressure on front cap	≤ 100 bar
Max. tightening torque of housing nut	10 Nm
Electrical connection	Cable with connector, M12 × 1
Cable quality	Ø 3.5 mm, PUR, 0.3 m
Core cross-section	3 × 0.14 mm <sup>2</sup>
<b>Environmental conditions</b>	
Ambient temperature	-25...+85 °C
Vibration resistance	55 Hz (1 mm)
Shock resistance	30 g (11 ms)
Protection class	IP67 IP68
MTTF	409 years acc. to SN 29500 (Ed. 99) 20 °C
Switching state	LED, Yellow, LED flashing: 0.8 s <sub>r</sub> < s ≤ s <sub>r</sub>

## Mounting instructions

### Mounting instructions/Description

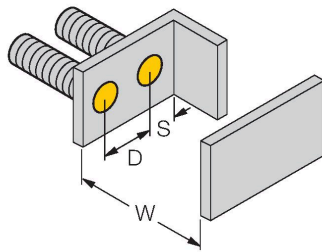

Distance D 22 mm

Distance W 9 mm

Distance T 24 mm

Distance S 6 mm

Distance G 18 mm

Diameter active area B  $\varnothing$  8 mm

The reduction factors listed below apply when flush-mounted in the following metals:

Steel: 1.0

Aluminum: 0.9

Brass: 0.9

Stainless steel: 1.0

## Accessories

MW08

6945008

Mounting bracket for threaded barrel sensors; material: Stainless steel A2 1.4301 (AISI 304)

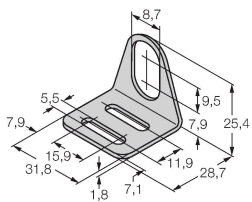

BSS-08

6901322

Mounting clamp for smooth and threaded barrel sensors; material: Polypropylene

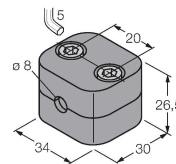

MBS80

69479

Mounting clamp for smooth barrel sensors; mounting block material: Anodized aluminum

