

SPECIFICATIONS	
RATED OPERATING DISTANCE	3.0mm = .118"
MOUNTING MODE	FLUSH
MIN. REPEAT ACCURACY	≤ 5%
TEMPERATURE DRIFT	≤ ± 10%
HYSTERESIS	20%
OPERATING TEMPERATURE	-25°C to +70°C (-13°F to +158°F)
RATED OPERATIONAL VOLTAGE	10-30 VDC
RESIDUAL RIPPLE	≤ 20%
RATED OPERATIONAL CURRENT	≤ 200 mA
NO-LOAD CURRENT	≤ 10 mA
RESIDUAL CURRENT	≤ 0.1 mA
RATED INSULATION VOLTAGE	≤ 0.5 kV
SHORT-CIRCUIT PROTECTED	YES
MAX VOLTAGE DROP	≤ 2.0 V
WIRE BREAKAGE PROTECTION	INCORPORATED
REVERSE POLARITY PROTECTION	INCORPORATED
OUTPUT FUNCTION	3-WIRE, NORMALLY OPEN, PNP
MAX. SWITCHING FREQUENCY	≤ 1.0 kHz
HOUSING MATERIAL	METAL, V2A (1.4305)
CABLE	∅3.5, TPU
SHOCK RESISTANCE	30 g, 11 ms
VIBRATION RESISTANCE	55 Hz, 1 mm AMPLITUDE (IN ALL 3 PLANES)
DEGREE OF PROTECTION	IP67/IP68
SWITCHING STATUS INDICATION	LED: YELLOW

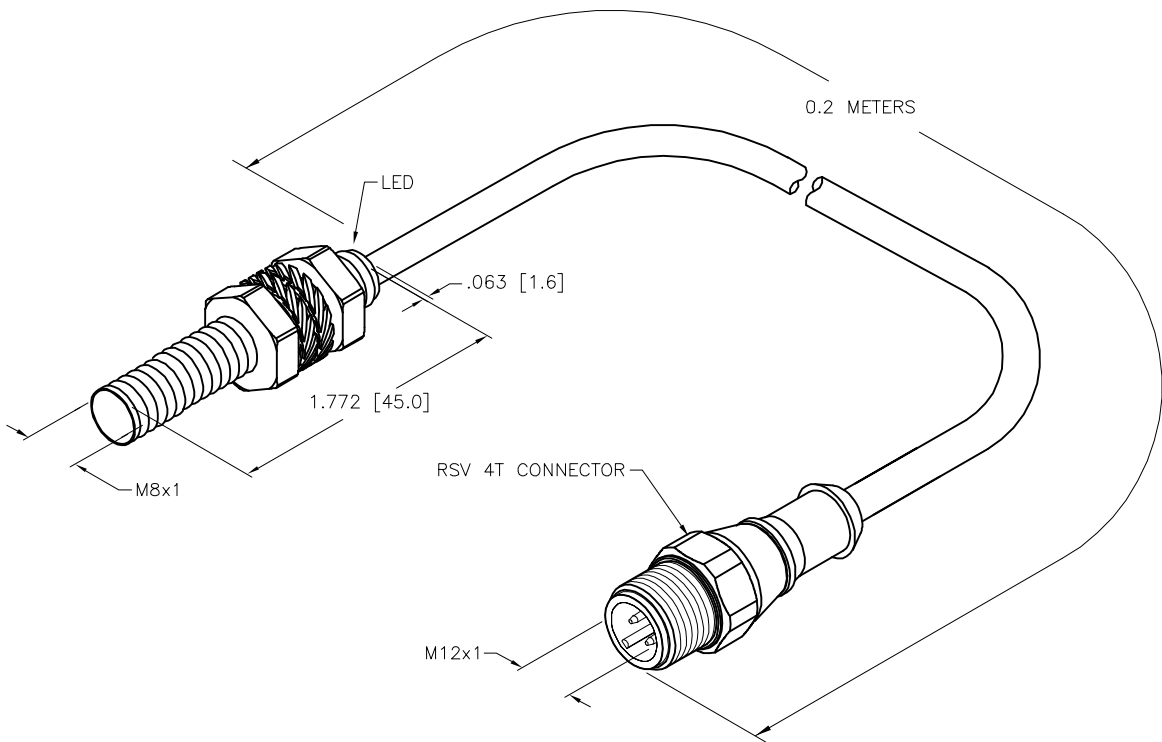

SOURCE DRAWING - FOR REFERENCE ONLY

RELATED DOCUMENTS		3RD ANGLE PROJECTION		THIS DRAWING IS CONFIDENTIAL AND THE PROPERTY OF TURCK INC. USE OF THIS DOCUMENT WITHOUT WRITTEN PERMISSION IS PROHIBITED.				3000 CAMPUS DRIVE MINNEAPOLIS, MN 55441 1-800-544-7769 (763) 553-7300 (763) 553-0708 fax www.turck.us	
1.				DRFT RDS		DATE 10/28/20		DESCRIPTION BI3-EG08FE-AP6X-0.2-RSV4T	
2.				APVD A.F.		SCALE 1=1.0			
3.		ALL DIMENSIONS DISPLAYED ON THIS DRAWING ARE FOR REFERENCE ONLY		UNIT OF MEASUREMENT INCH [MILLIMETER]		IDENTIFICATION NO. 100025029		REV A	
4.									
MATERIAL SEE SPECS		CONTACT TURCK FOR MORE INFORMATION		DO NOT SCALE THIS DRAWING		FILE: 100025029		SHEET 1 OF 1	
FINISH SEE SPECS									
A	DRAWING RELEASE	RDS	10/28/20						
REV	DESCRIPTION	BY	DATE	ECO NO.					