

### WIRING DIAGRAM

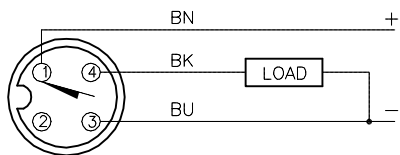

OUTPUT: AP6X2

SHORT-CIRCUIT AND OVERLOAD PROTECTED

### SPECIFICATIONS

OPERATING VOLTAGE	10-30 VDC
RESIDUAL RIPPLE	≤10%
HYSTERESIS	3-15% (5% TYPICAL)
VOLTAGE DROP ACROSS CONDUCTING SENSOR	≤1.8 V at 200 mA
OUTPUT FUNCTION	NORMALLY OPEN 3-WIRE DC SELF-CONTAINED
SHORT-CIRCUIT PROTECTED	YES
TRIGGER CURRENT FOR OVERLOAD PROTECTION	≥ 220 mA
CONTINUOUS LOAD CURRENT	≤ 200 mA
RESIDUAL CURRENT	<10 μA
NO-LOAD CURRENT	15 mA
TIME DELAY BEFORE AVAILABILITY	< 8 ms
POWER-ON EFFECT PROTECTION	INCORPORATED
REVERSE POLARITY PROTECTION	INCORPORATED
WIRE-BREAK PROTECTION	INCORPORATED
PROTECTION AGAINST TRANSIENTS	EN 60947-5-2
OPERATING TEMPERATURE	0°C TO +70°C (+32°F TO +158°F)
ENCLOSURE	MEETS NEMA 1, 3, 4, 6, 13 AND IEC IP67
SHOCK	30 g, 11 ms
VIBRATION	55 Hz, 1 mm AMPLITUDE (IN ALL 3 PLANES)
LED FUNCTION	GREEN: POWER ON GREEN FLASHING: SHORT-CIRCUIT INDICATION YELLOW: OUTPUT ENERGIZED
RATED OPERATING DISTANCE	20 mm = .787" (NOMINAL)
SWITCHING FREQUENCY	250 Hz
REPEATABILITY	≤ 2% of RATED OPERATING DISTANCE
EMBEDDABLE (SHIELDED)	YES

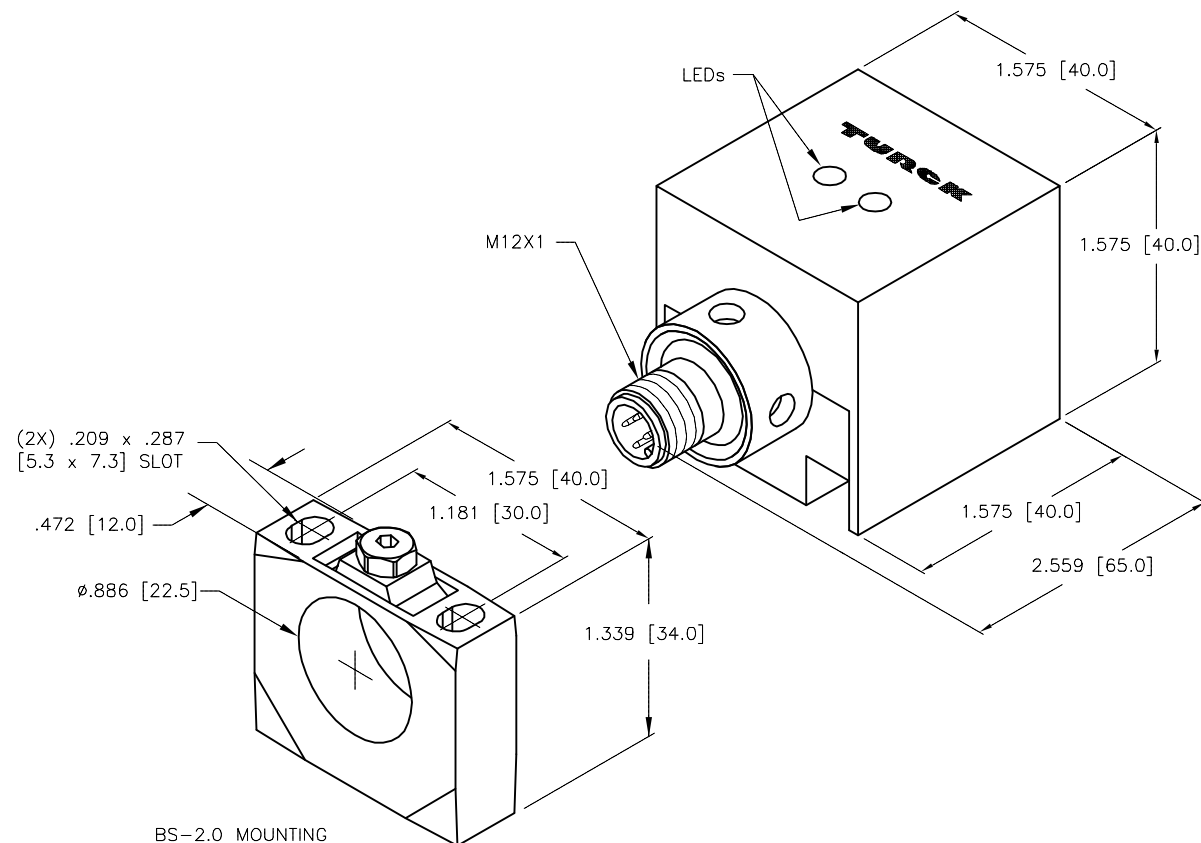

BS-2.0 MOUNTING BRACKET

SOURCE DRAWING - FOR REFERENCE ONLY

NOTES:

1. SENSING HEAD CAN ROTATE TO 5 DIFFERENT SENSING POSITIONS.
2. UPROX HAS WELD FIELD IMMUNITY, SENSOR IS SUITABLE FOR USE ON RESISTANCE MACHINES.

RELATED DOCUMENTS 1. 2. 3. 4.	3RD ANGLE PROJECTION 	THIS DRAWING IS CONFIDENTIAL AND THE PROPERTY OF TURCK INC. USE OF THIS DOCUMENT WITHOUT WRITTEN PERMISSION IS PROHIBITED.		3000 CAMPUS DRIVE MINNEAPOLIS, MN 55441 1-800-544-7769 (763) 553-7300 (763) 553-0708 fax www.turck.us	
	MATERIAL HOUSING: GD-ALSI12 FRONTCAP: THERMOSET PLASTIC	ALL DIMENSIONS DISPLAYED ON THIS DRAWING ARE FOR REFERENCE ONLY  CONTACT TURCK FOR MORE INFORMATION	DRFT NF APVD A.F.	DATE 10/05/16 SCALE NONE	DESCRIPTION BI20U-CA40-AP6X2-H1141 W/BS2.0
FINISH	UNIT OF MEASUREMENT <b>INCH [ MILLIMETER ]</b>	IDENTIFICATION NO. 1627298		REV C	
DO NOT SCALE THIS DRAWING		FILE: 1627298		SHEET 1 OF 1	

C	UPDATE DESCRIPTION	RDS	06/20/19	500000000158
REV	DESCRIPTION	BY	DATE	ECO NO.