

WIRING DIAGRAM

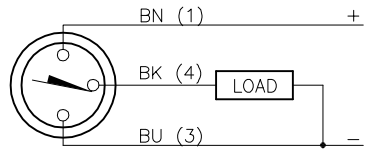

OUTPUT: AP6X

SHORT-CIRCUIT AND OVERLOAD PROTECTED

SPECIFICATIONS

| | |
|------------------------------|----------------------------------|
| RATED OPERATING DISTANCE | 2 mm [.079"] |
| MOUNTING MODE | FLUSH |
| TEMPERATURE DRIFT | ≤ ±10% |
| HYSTERESIS | 3-15% |
| MIN. REPEAT ACCURACY | ≤2% |
| OPERATING TEMPERATURE | -25°C to +70°C (-13°F to +158°F) |
| RATED OPERATIONAL VOLTAGE | 10-30 VDC |
| RESIDUAL RIPPLE | ≤10% |
| DC RATED OPERATIONAL CURRENT | ≤150 mA |
| NO-LOAD CURRENT | ≤15 mA |
| RESIDUAL CURRENT | ≤0.1 mA |
| RATED INSULATION VOLTAGE | ≤0.5 kV |
| SHORT-CIRCUIT PROTECTED | YES |
| MAX. VOLTAGE DROP | ≤1.8 V |
| SWITCHING FREQUENCY | ≤2.0 kHz |
| WIRE-BREAK PROTECTION | INCORPORATED |
| REVERSE POLARITY PROTECTION | INCORPORATED |
| OUTPUT FUNCTION | 3-WIRE, NORMALLY OPEN, PNP |
| HOUSING MATERIAL/COLOR | PLASTIC, PP/YELLOW |
| ACTIVE FACE | PLASTIC, PA12-GF20 |
| CABLE | ∅3.0, TPU |
| VIBRATION RESISTANCE | 55 Hz (IN ALL 3 PLANES) |
| SHOCK RESISTANCE | 30 g, 11 ms |
| DEGREE OF PROTECTION | IP 67 |
| SWITCHING STATUS INDICATION | LED, YELLOW |

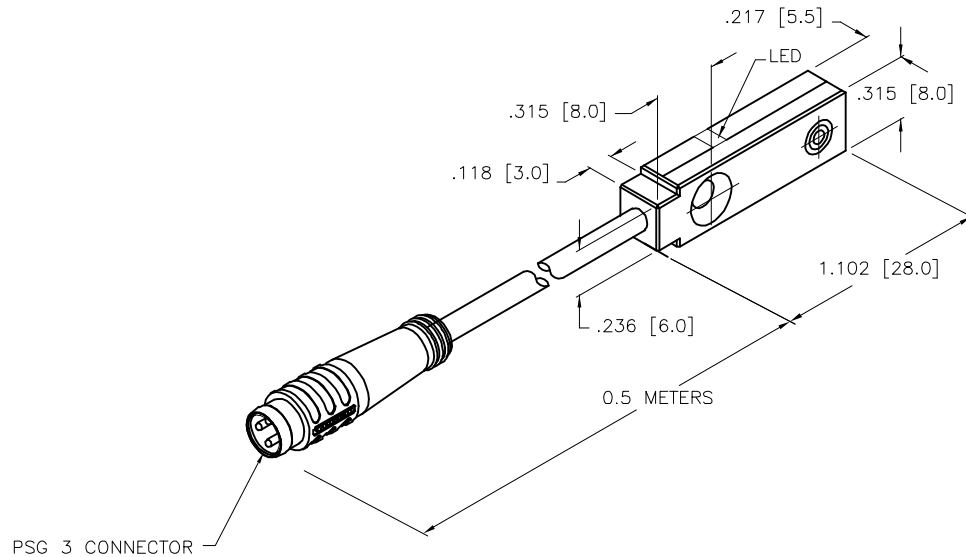

SOURCE DRAWING - FOR REFERENCE ONLY

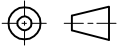
| | | | | | | | |
|-------------------|--|---|----------------------------|--|--------------------|---|--|
| RELATED DOCUMENTS | | 3RD ANGLE PROJECTION | | THIS DRAWING IS CONFIDENTIAL AND THE PROPERTY OF TURCK INC. USE OF THIS DOCUMENT WITHOUT WRITTEN PERMISSION IS PROHIBITED. | |  3000 CAMPUS DRIVE MINNEAPOLIS, MN 55441 1-800-544-7769 (763) 553-7300 (763) 553-0708 fax www.turck.us | |
| 1. | |  | DRFT | RDS | DATE | 11/23/10 | DESCRIPTION BI2-Q5.5-AP6X-0.5M-PSG3 |
| 2. | | | APVD | | SCALE | 1=1.0 | |
| 3. | | ALL DIMENSIONS DISPLAYED ON THIS DRAWING ARE FOR REFERENCE ONLY CONTACT TURCK FOR MORE INFORMATION | UNIT OF MEASUREMENT | | IDENTIFICATION NO. | | REV |
| 4. | | | INCH [MILLIMETER] | | 1613092 | | D |
| MATERIAL | | SEE SPECIFICATIONS | | DO NOT SCALE THIS DRAWING | | FILE: 1613092 | |
| FINISH | | SEE SPECIFICATIONS | | | | SHEET 1 OF 1 | |

| | | | | |
|-----|---------------------|----|----------|---------|
| D | UPDATED TEMP RATING | ER | 05/14/21 | 76720 |
| REV | DESCRIPTION | BY | DATE | ECO NO. |