

WIRING DIAGRAM

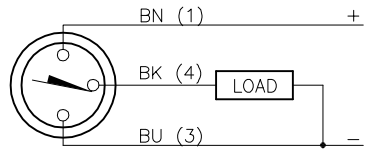

OUTPUT: AP6X

SHORT-CIRCUIT AND OVERLOAD PROTECTED

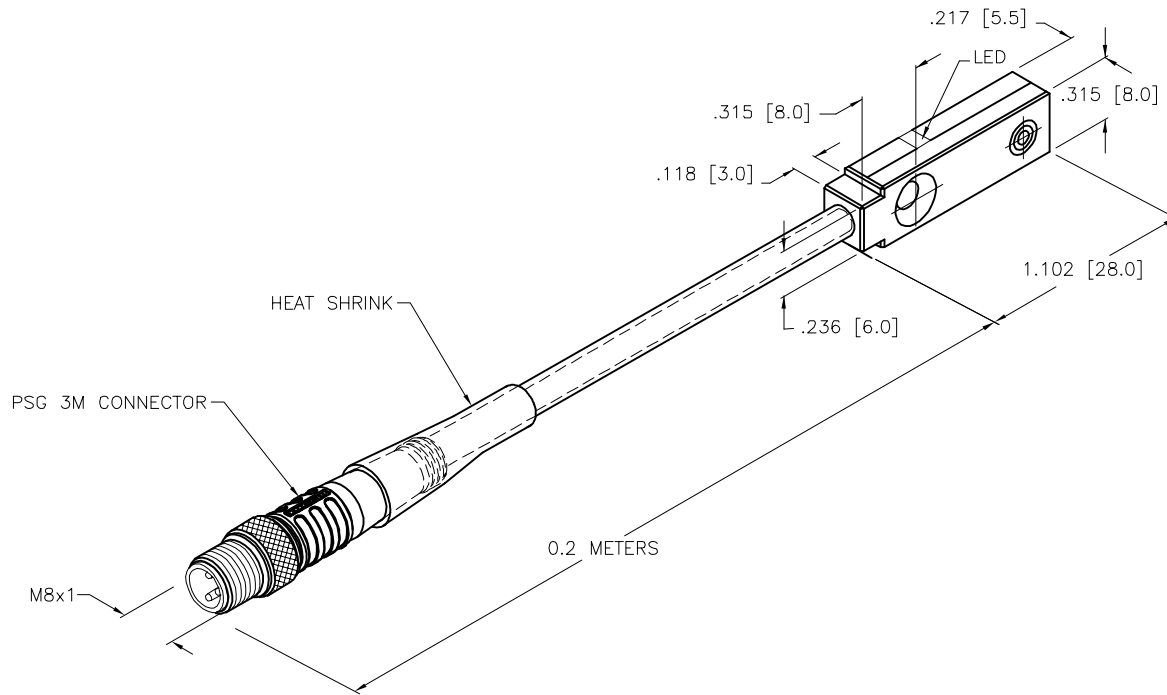

SPECIFICATIONS

RATED OPERATING DISTANCE	2 mm [.079"]
MOUNTING MODE	FLUSH
TEMPERATURE DRIFT	≤ ±10%
HYSTERESIS	3-15%
MIN. REPEAT ACCURACY	≤2%
OPERATING TEMPERATURE	-25°C to +70°C (-13°F to +158°F)
RATED OPERATIONAL VOLTAGE	10-30 VDC
RESIDUAL RIPPLE	≤10%
DC RATED OPERATIONAL CURRENT	≤150 mA
NO-LOAD CURRENT	≤15 mA
RESIDUAL CURRENT	≤0.1 mA
RATED INSULATION VOLTAGE	≤0.5 kV
SHORT-CIRCUIT PROTECTED	YES
MAX. VOLTAGE DROP	≤1.8 V
SWITCHING FREQUENCY	≤2.0 kHz
WIRE-BREAK PROTECTION	INCORPORATED
REVERSE POLARITY PROTECTION	INCORPORATED
OUTPUT FUNCTION	3-WIRE, NORMALLY OPEN, PNP
HOUSING MATERIAL/COLOR	PLASTIC, PP/YELLOW
ACTIVE FACE	PLASTIC, PA12-GF20
CABLE	∅3.0, TPU
VIBRATION RESISTANCE	55 Hz (IN ALL 3 PLANES)
SHOCK RESISTANCE	30 g, 11 ms
DEGREE OF PROTECTION	IP 67
SWITCHING STATUS INDICATION	LED, YELLOW

SOURCE DRAWING - FOR REFERENCE ONLY

1. "/S1154" DESIGNATES WELDGUARD COATED SENSOR TO BE USED AS BASE UNIT. USE PTFE TUBING OVER SENSOR CABLE.

- PTFE TUBING STARTS AT SENSOR END, AND GETS CAPTURED IN THE CONNECTOR MOLDING MATERIAL

- SLIDE 35MM OF SHRINK TUBING TO OVERLAP CONNECTOR MOLD BODY AND PTFE TUBING

RELATED DOCUMENTS		3RD ANGLE PROJECTION		THIS DRAWING IS CONFIDENTIAL AND THE PROPERTY OF TURCK INC. USE OF THIS DOCUMENT WITHOUT WRITTEN PERMISSION IS PROHIBITED.		3000 CAMPUS DRIVE MINNEAPOLIS, MN 55441 1-800-544-7769 (763) 553-7300 (763) 553-0708 fax www.turck.us	
1. 2. 3. 4.				DRFT RDS DATE 03/02/15 APVD A.F. SCALE 1=1.0		DESCRIPTION B12-Q5.5-AP6X-0.2-PSG3M/S1154	
MATERIAL		ALL DIMENSIONS DISPLAYED ON THIS DRAWING ARE FOR REFERENCE ONLY		UNIT OF MEASUREMENT		IDENTIFICATION NO.	
SEE SPECIFICATIONS		CONTACT TURCK FOR MORE INFORMATION		INCH [MILLIMETER] DO NOT SCALE THIS DRAWING		16130019 REV C	
FINISH		SEE SPECIFICATIONS		FILE: 16130019		SHEET 1 OF 1	

C	UPDATE TEMPERTURE SPEC	RDS	05/14/21	76718
REV	DESCRIPTION	BY	DATE	ECO NO.