

WIRING DIAGRAM

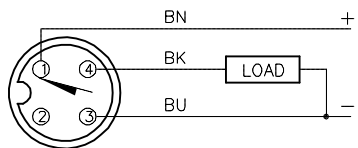

OUTPUT: AP6X

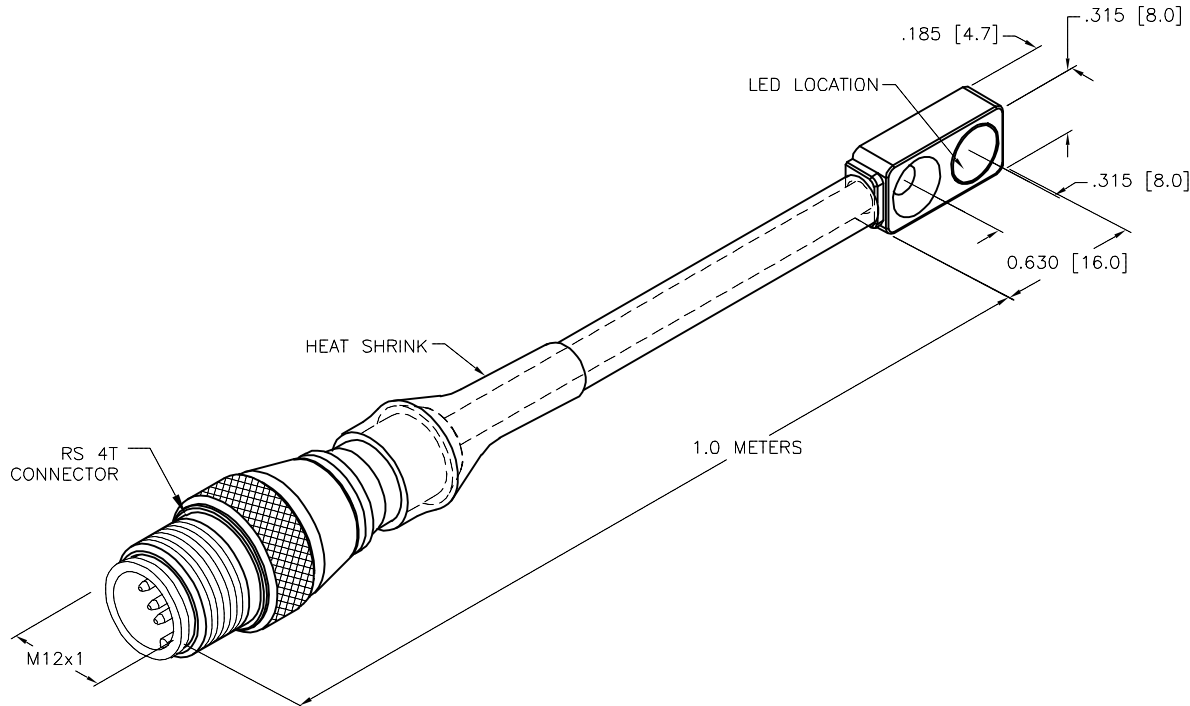

SPECIFICATIONS

RATED OPERATING DISTANCE	2mm = .079" (NOMINAL)
MOUNTING MODE	FLUSH
TEMPERATURE DRIFT	≤ ±10%
HYSTERESIS	3-15%
MIN. REPEAT ACCURACY	≤ 2%
OPERATING TEMPERATURE	0°C to +85°C (+32°F to +185°F)
RATED OPERATIONAL VOLTAGE	10-30 VDC
RESIDUAL RIPPLE	≤ 10%
RATED OPERATIONAL CURRENT	≤ 100 mA
NO-LOAD CURRENT	≤ 15 mA
RESIDUAL CURRENT	≤ 0.1 mA
RATED INSULATION VOLTAGE	≤ 0.5 kV
SHORT-CIRCUIT PROTECTION	YES, CYCLIC
MAX. VOLTAGE DROP	≤ 1.8 V
WIRE BREAKAGE PROTECTION	INCORPORATED
REVERSE POLARITY PROTECTION	INCORPORATED
OUTPUT FUNCTION	3-WIRE, NORMALLY OPEN, PNP
MAX. SWITCHING FREQUENCY	≤ 1 kHz
HOUSING MATERIAL	METAL, GD-ZN/NICKEL PLATED
ACTIVE FACE	PLASTIC, PA-12
CABLE	∅3.0, TPU/GRAY
VIBRATION RESISTANCE	55 Hz, 1 mm AMPLITUDE (IN ALL 3 PLANES)
SHOCK RESISTANCE	30 g, 11 ms
DEGREE OF PROTECTION	IP67
SWITCHING STATUS INDICATION	LED, YELLOW

SOURCE DRAWING - FOR REFERENCE ONLY

NOTES:

- LED LOCATION IS AT THE EDGE OF THE SENSING FACE.
- "/S1154" DESIGNATES WELDGUARD-COATED SENSOR TO BE USED AS BASE UNIT. USE PTFE TUBING OVER SENSOR CABLE.
 - PTFE TUBING STARTS AT SENSOR END, AND GETS CAPTURED IN THE CONNECTOR MOLDING MATERIAL.
 - SLIDE 35MM OF SHRINK TUBING TO OVERLAP CONNECTOR MOLD BODY AND PTFE TUBING.

RELATED DOCUMENTS 1. 2. 3. 4.	3RD ANGLE PROJECTION	THIS DRAWING IS CONFIDENTIAL AND THE PROPERTY OF TURCK INC. USE OF THIS DOCUMENT WITHOUT WRITTEN PERMISSION IS PROHIBITED.		3000 CAMPUS DRIVE MINNEAPOLIS, MN 55441 1-800-544-7769 (763) 553-7300 (763) 553-0708 fax www.turck.us	
	MATERIAL	DRFT NF	DATE 05/29/18	DESCRIPTION BI2-Q4.7-AP6X-1-RS4T/S1154	
FINISH	ALL DIMENSIONS DISPLAYED ON THIS DRAWING ARE FOR REFERENCE ONLY	APVD A.F.	SCALE 1=.8	IDENTIFICATION NO. 16140076	
CONTACT TURCK FOR MORE INFORMATION		UNIT OF MEASUREMENT INCH [MILLIMETER]		REV A	
DO NOT SCALE THIS DRAWING		FILE: 16140076		SHEET 1 OF 1	

A	DRAWING RELEASE	NF	05/30/18	
REV	DESCRIPTION	BY	DATE	ECO NO.