

### WIRING DIAGRAM

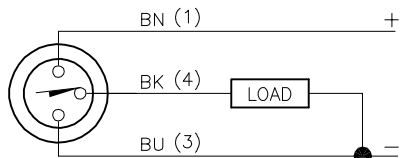

OUTPUT: AP6X

SHORT-CIRCUIT AND OVERLOAD PROTECTED

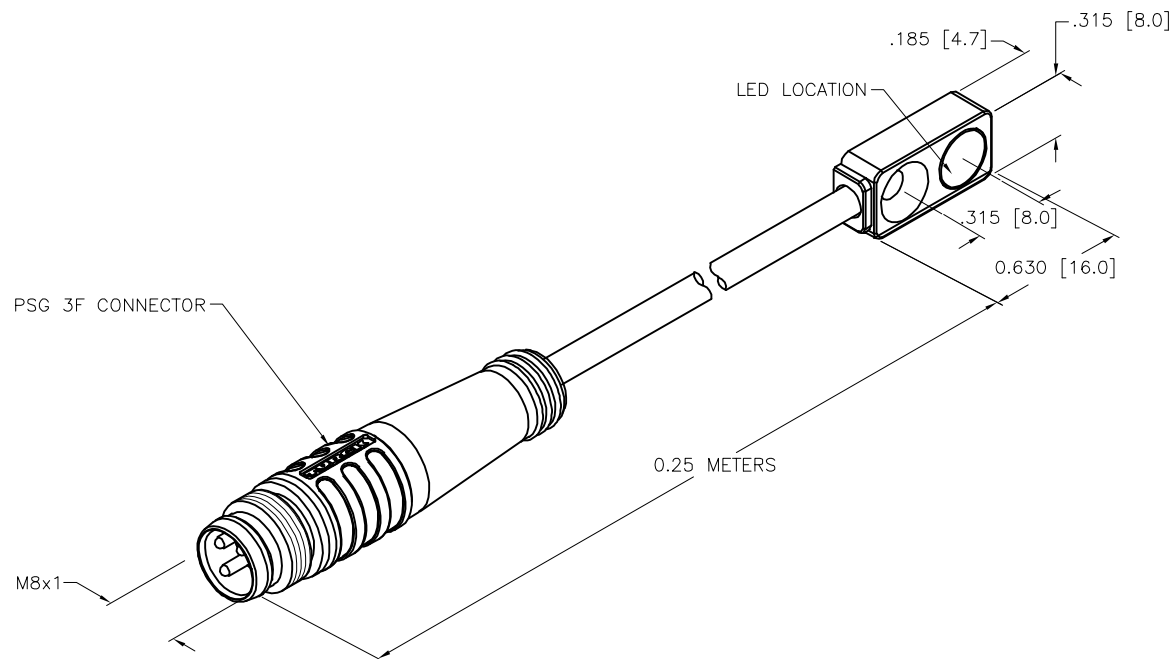

### SPECIFICATIONS

RATED OPERATING DISTANCE	2mm = .079" (NOMINAL)
MOUNTING MODE	FLUSH
TEMPERATURE DRIFT	≤ ±10%
HYSTERESIS	3-15%
MIN. REPEAT ACCURACY	≤ 2%
OPERATING TEMPERATURE	0°C to +85°C (+32°F to +185°F)
RATED OPERATIONAL VOLTAGE	10-30 VDC
RESIDUAL RIPPLE	≤ 10%
RATED OPERATIONAL CURRENT	≤ 100 mA
NO-LOAD CURRENT	≤ 15 mA
RESIDUAL CURRENT	≤ 0.1 mA
RATED INSULATION VOLTAGE	≤ 0.5 kV
SHORT-CIRCUIT PROTECTION	YES, CYCLIC
MAX. VOLTAGE DROP	≤ 1.8 V
WIRE BREAKAGE PROTECTION	INCORPORATED
REVERSE POLARITY PROTECTION	INCORPORATED
OUTPUT FUNCTION	3-WIRE, NORMALLY OPEN, PNP
MAX. SWITCHING FREQUENCY	≤ 1 kHz
HOUSING MATERIAL	METAL, GD-ZN/NICKEL PLATED
ACTIVE FACE	PLASTIC, PA-12
CABLE	Ø3.0, TPU/GRAY
VIBRATION RESISTANCE	55 Hz, 1 mm AMPLITUDE (IN ALL 3 PLANES)
SHOCK RESISTANCE	30 g, 11 ms
DEGREE OF PROTECTION	IP67
SWITCHING STATUS INDICATION	LED, YELLOW

SOURCE DRAWING - FOR REFERENCE ONLY

#### NOTES:

- LED LOCATION IS AT THE EDGE OF THE SENSING FACE.
- "/SV" DESIGNATES SPECIAL PACKAGING FOR VENDING MACHINES.

RELATED DOCUMENTS 1. 2. 3. 4.	3RD ANGLE PROJECTION 	THIS DRAWING IS CONFIDENTIAL AND THE PROPERTY OF TURCK INC. USE OF THIS DOCUMENT WITHOUT WRITTEN PERMISSION IS PROHIBITED.		3000 CAMPUS DRIVE MINNEAPOLIS, MN 55441 1-800-544-7769 (763) 553-7300 (763) 553-0708 fax www.turck.us	
	MATERIAL	DRFT NF	DATE 07/23/19	DESCRIPTION BI2-Q4.7-AP6X-0.25-PSG3F/SV	
FINISH	ALL DIMENSIONS DISPLAYED ON THIS DRAWING ARE FOR REFERENCE ONLY	APVD A.F.	SCALE 1=.8	IDENTIFICATION NO. 100008614	
	CONTACT TURCK FOR MORE INFORMATION	UNIT OF MEASUREMENT <b>INCH [ MILLIMETER ]</b>		REV A	
A	DRAWING RELEASE	NF	08/09/19	DO NOT SCALE THIS DRAWING	
REV	DESCRIPTION	BY	DATE	ECO NO.	FILE: 100008614
					SHEET 1 OF 1