

WIRING DIAGRAM

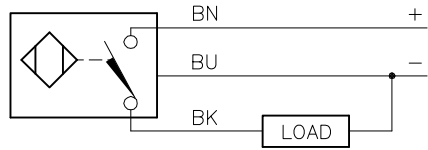

OUTPUT: AP6X

SHORT-CIRCUIT AND OVERLOAD PROTECTED

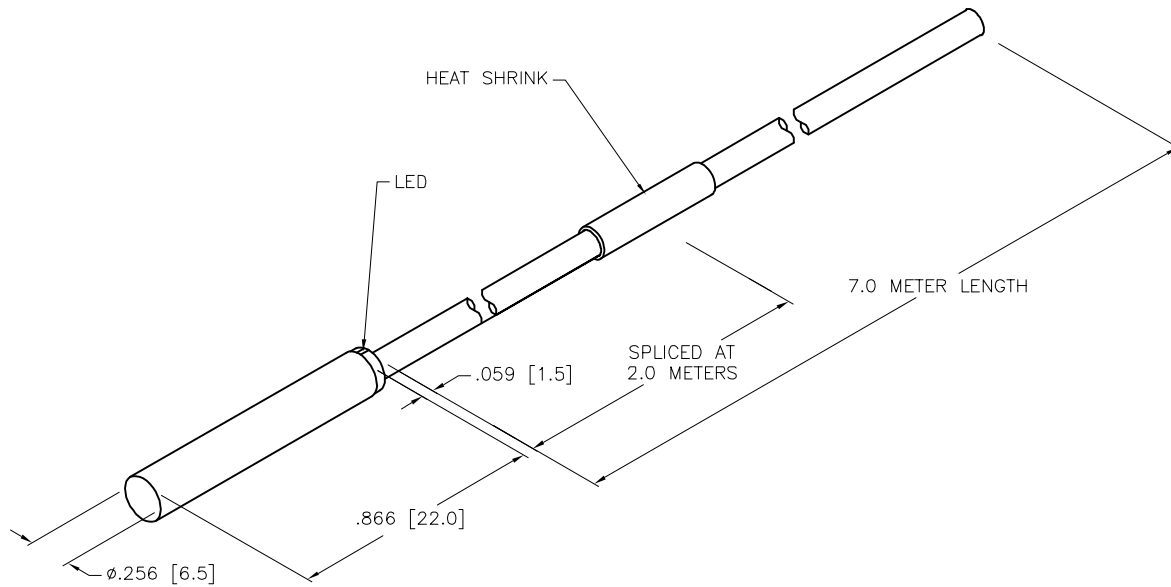

SPECIFICATIONS

RATED OPERATING DISTANCE	2.0mm = .079"
MOUNTING MODE	FLUSH
TEMPERATURE DRIFT	≤ ±10%
HYSTERESIS	20%
MIN. REPEAT ACCURACY	≤ 2%
OPERATING TEMPERATURE	-25°C to +70°C (-13°F to +158°F)
RATED OPERATIONAL VOLTAGE	10-30 VDC
RESIDUAL RIPPLE	≤ 10%
DC RATED OPERATIONAL CURRENT	≤ 150 mA
NO LOAD CURRENT	≤ 15 mA
RESIDUAL CURRENT	≤ 0.1 mA
RATED INSULATION VOLTAGE	≤ 0.5 kV
SHORT-CIRCUIT PROTECTION	YES
MAX. VOLTAGE DROP	≤ 1.8 V
WIRE BREAKAGE PROTECTION	YES
REVERSE POLARITY PROTECTION	YES
OUTPUT FUNCTION	3-WIRE, NORMALLY OPEN, PNP
MAX. SWITCHING FREQUENCY	≤ 3.0 kHz
HOUSING MATERIAL	STAINLESS STEEL, 1.4305 (AISI 303)
ACTIVE FACE	PLASTIC, PA6.6
END CAP	PLASTIC, PP
CABLE	ø3.3, TPU
VIBRATION RESISTANCE	55 Hz, (1mm) IN ALL 3 PLANES
SHOCK RESISTANCE	30 g, (11 ms)
DEGREE OF PROTECTION	IP67
SWITCHING STATUS INDICATION	LED: YELLOW

SOURCE DRAWING - FOR REFERENCE ONLY

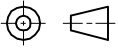
RELATED DOCUMENTS		3RD ANGLE PROJECTION		THIS DRAWING IS CONFIDENTIAL AND THE PROPERTY OF TURCK INC. USE OF THIS DOCUMENT WITHOUT WRITTEN PERMISSION IS PROHIBITED.		 3000 CAMPUS DRIVE MINNEAPOLIS, MN 55441 1-800-544-7769 (763) 553-7300 (763) 553-0708 fax www.turck.us	
1.			DRFT	RDS	DATE	01/25/18	DESCRIPTION BI2-EH6.5K-AP6X 7M SPLICED
2.			APVD	A.F.	SCALE	1=1.0	
3.		ALL DIMENSIONS DISPLAYED ON THIS DRAWING ARE FOR REFERENCE ONLY CONTACT TURCK FOR MORE INFORMATION	UNIT OF MEASUREMENT		IDENTIFICATION NO.		REV
4.			INCH [MILLIMETER]		4610098		B
MATERIAL		DO NOT SCALE THIS DRAWING		FILE: 4610098		SHEET 1 OF 1	
FINISH							

B	UPDATE SPECS	RDS	01/11/21	76407
REV	DESCRIPTION	BY	DATE	ECO NO.