

BI2-EG08K-AP6X-V1131/S1589

Inductive Sensor – With Weldguard® coating

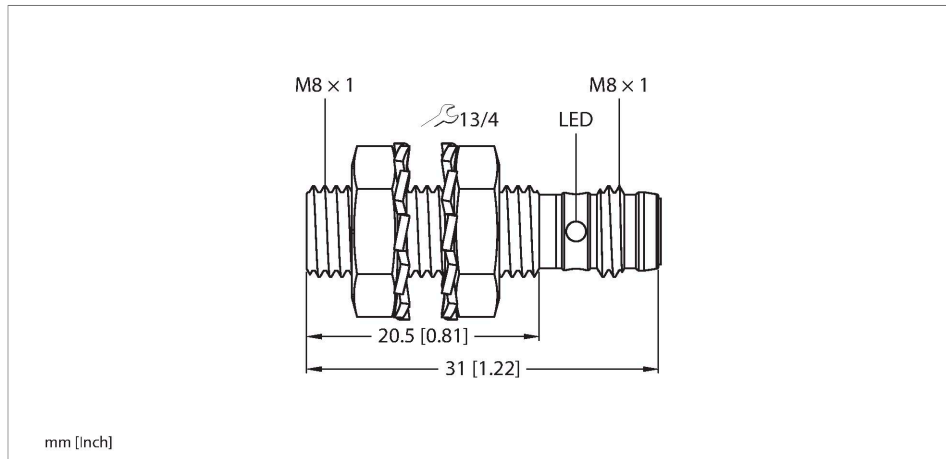

Features

- M8 × 1 threaded barrel
- Stainless steel, 1.4305 (AISI 303)
- Large sensing range
- DC 3-wire, 10...30 VDC
- NO contact, PNP output
- M8 x 1 male connector

Wiring diagram

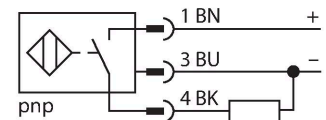

Technical data

Type	BI2-EG08K-AP6X-V1131/S1589
ID	46694003
Special version	S1589 Corresponds to: With weldguard coating
General data	
Rated switching distance	2 mm
Mounting conditions	Flush
Secured operating distance	≤ (0.81 × S _n) mm
Correction factors	St37 = 1; Al = 0.3; stainless steel = 0.7; Ms = 0.4
Repeat accuracy	≤ 2 % of full scale
Hysteresis	20 %
Electrical data	
Operating voltage U _B	10...30 VDC
Ripple U _{ss}	≤ 10 % U _{Bmax}
DC rated operating current I _B	≤ 150 mA
No-load current	≤ 15 mA
Residual current	≤ 0.1 mA
Isolation test voltage	0.5 kV
Short-circuit protection	yes/Cyclic
Voltage drop at I _B	≤ 1.8 V
Wire break/reverse polarity protection	yes/Complete
Output function	3-wire, NO contact, PNP
Switching frequency	3 kHz

Functional principle

Inductive sensors detect metal objects contactless and wear-free. For this purpose they use a high-frequency electromagnetic AC field that interacts with the target. The sensors hosting a ferrite core coil generate the AC field through an LC resonant circuit.

Technical data

Mechanical data	
Design	Threaded barrel, M8 x 1
Dimensions	31 mm
Housing material	Stainless steel, 1.4305 (AISI 303)
Active area material	Plastic, PA6.6
Max. tightening torque of housing nut	5 Nm
Electrical connection	Connector, M8 x 1
Environmental conditions	
Ambient temperature	-25...+70 °C
Vibration resistance	55 Hz (1 mm)
Shock resistance	30 g (11 ms)
Protection class	IP67
MTTF	2283 years acc. to SN 29500 (Ed. 99) 40 °C
Switching state	LED, Yellow

Mounting instructions

Mounting instructions/Description



Distance D	2 x B
Distance W	3 x Sn
Distance T	3 x B
Distance S	1.5 x B
Distance G	6 x Sn
Diameter active area B	Ø 8 mm

Accessories

BST-08B

6947210

Mounting clamp for threaded barrel sensors, with dead-stop; material: PA6



QM-08

6945100

Quick-mount bracket with dead-stop, chrome-plated brass, male thread M12 x 1. Note: The switching distance of proximity switches may be reduced through the use of quick-mount brackets.



MW08

6945008

Mounting bracket for threaded barrel sensors; material: Stainless steel A2 1.4301 (AISI 304)



BSS-08

6901322

Mounting clamp for smooth and threaded barrel sensors; material: Polypropylene



MBS80

69479

Mounting clamp for smooth barrel sensors; mounting block material: Anodized aluminum

