

WIRING DIAGRAM

LOCKNUT LN-SS08

SPECIFICATIONS

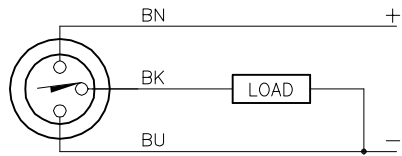

OUTPUT: AP6X

SHORT-CIRCUIT AND OVERLOAD PROTECTED

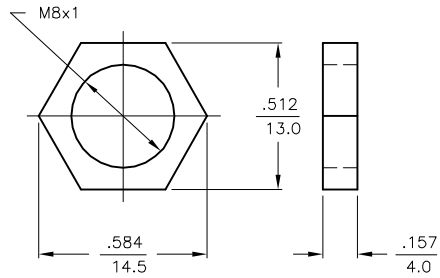

RATED OPERATING DISTANCE	2mm =.079"
MOUNTING MODE	FLUSH
MIN. REPEAT ACCURACY	≤ 2%
TEMPERATURE DRIFT	≤ ±10%
HYSTERESIS	20%
OPERATING TEMPERATURE	-25°C to +70°C (-13°F to +158°F)
RATED OPERATIONAL VOLTAGE	10-30 VDC
MAX. RIPPLE	≤ 10%
RATED OPERATIONAL CURRENT	≤ 150 mA
NO-LOAD CURRENT	≤ 15 mA
MAX. OFF-STATE CURRENT	≤ 0.1 mA
RATED INSULATION VOLTAGE	≤ 0.5 kV
SHORT-CIRCUIT PROTECTED	YES
MAX. VOLTAGE DROP	≤ 1.8 V
REVERSE POLARITY PROTECTION	INCORPORATED
WIRE-BREAK PROTECTION	INCORPORATED
OUTPUT FUNCTION	NORMALLY OPEN, 3-WIRE, PNP
MAX. SWITCHING FREQUENCY	≤ 3 kHz
HOUSING MATERIAL	STAINLESS STEEL, 1.4305 (AISI 303)
ACTIVE FACE	PLASTIC, PA6.6
END CAP	PLASTIC, PP
CABLE	ø3.3, Lify-11Y, TPU
SHOCK RESISTANCE	30 g, 11 ms
VIBRATION RESISTANCE	55 Hz, 1 mm AMPLITUDE (IN ALL 3 PLANES)
DEGREE OF PROTECTION	IP67
SWITCHING STATUS INDICATION	LED: YELLOW

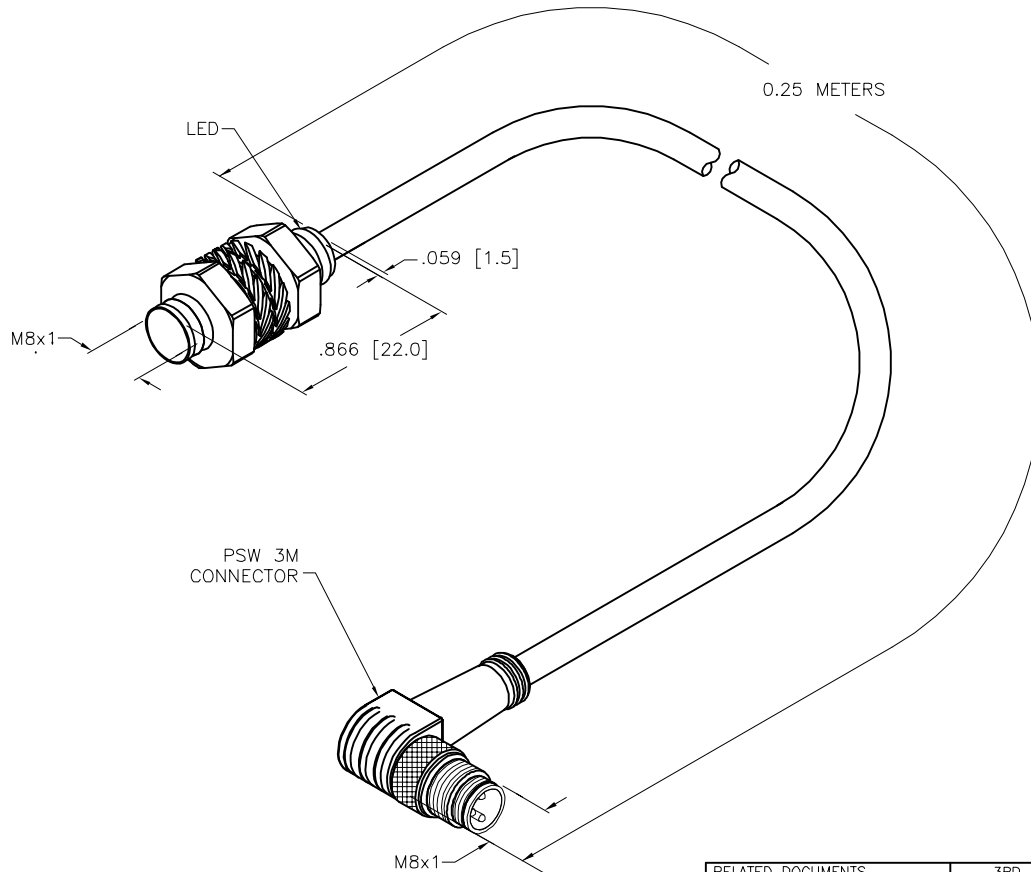

SOURCE DRAWING - FOR REFERENCE ONLY

RELATED DOCUMENTS 1. 2. 3. 4.	3RD ANGLE PROJECTION 	THIS DRAWING IS CONFIDENTIAL AND THE PROPERTY OF TURCK INC. USE OF THIS DOCUMENT WITHOUT WRITTEN PERMISSION IS PROHIBITED.		3000 CAMPUS DRIVE MINNEAPOLIS, MN 55441 1-800-544-7769 (763) 553-7300 (763) 553-0708 fax www.turck.us	
	MATERIAL	ALL DIMENSIONS DISPLAYED ON THIS DRAWING ARE FOR REFERENCE ONLY	DRFT RDS APVD	DATE 03/17/09 SCALE 1=1.0	DESCRIPTION BI2-EG08K-AP6X-0.25-PSW3M
FINISH	CONTACT TURCK FOR MORE INFORMATION	UNIT OF MEASUREMENT <b>INCH [ MILLIMETER ]</b>		IDENTIFICATION NO. 46694991	REV E
E UPDATE SPECS RDS 02/24/21 76535	BY DATE ECO NO.	DO NOT SCALE THIS DRAWING		FILE: 46694991	SHEET 1 OF 1

E	UPDATE SPECS	RDS	02/24/21	76535
REV	DESCRIPTION	BY	DATE	ECO NO.