

SPECIFICATIONS

RATED OPERATING DISTANCE	2mm [.079]
MOUNTING MODE	FLUSH
MIN. REPEAT ACCURACY	≤ 2%
TEMPERATURE DRIFT	≤ ±10%
HYSTERESIS	20%
OPERATING TEMPERATURE	-25°C to +70°C (-13°F to +158°F)
OPERATING VOLTAGE	10-30 VDC
RESIDUAL RIPPLE	≤ 10%
DC RATED OPERATIONAL CURRENT	≤150 mA
NO-LOAD CURRENT	≤ 15 mA
RESIDUAL CURRENT	≤ 0.1 mA
RATED INSULATION VOLTAGE	≤ 0.5 kV
SHORT-CIRCUIT PROTECTED	YES
MAX VOLTAGE DROP	≤ 1.8 V
WIRE-BREAKAGE PROTECTION	YES
REVERSE POLARITY PROTECTION	YES
OUTPUT FUNCTION	3-WIRE, NORMALLY OPEN, PNP
SWITCHING FREQUENCY	≤ 3.0 kHz
HOUSING MATERIAL	STAINLESS STEEL, 1.4305 (AISI 303)
ACTIVE FACE MATERIAL	PLASTIC, PA6.6
END CAP MATERIAL	PLASTIC, PP
CABLE	∅3.3, LIFY-11Y, TPU
SHOCK RESISTANCE	30 g, 11 ms
VIBRATION RESISTANCE	55 Hz, 1 mm AMPLITUDE (IN ALL 3 PLANES)
DEGREE OF PROTECTION	IP67
SWITCHING STATUS INDICATION	LED: YELLOW

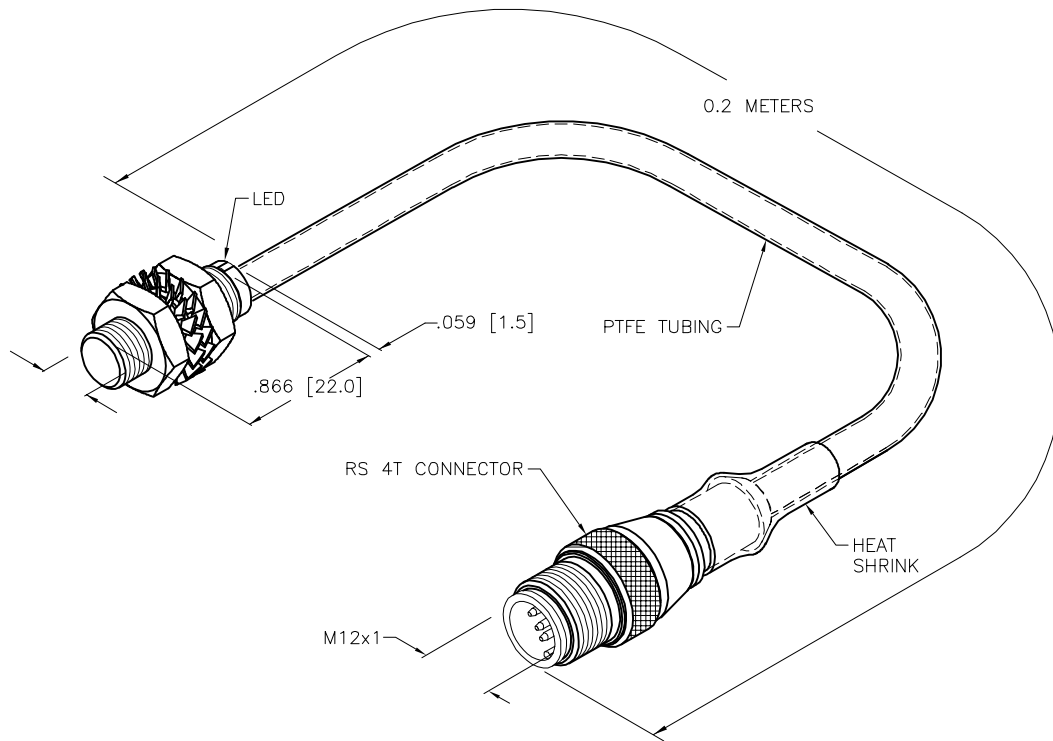

SOURCE DRAWING - FOR REFERENCE ONLY

1. "/S1154" DESIGNATES WELDGUARD COATED SENSOR TO BE USED AS BASE UNIT. USE PTFE TUBING OVER SENSOR CABLE.

- PTFE TUBING STARTS AT SENSOR END, AND GETS CAPTURED IN THE CONNECTOR MOLDING MATERIAL

- SLIDE 35MM OF SHRINK TUBING TO OVERLAP CONNECTOR MOLD BODY AND PTFE TUBING

RELATED DOCUMENTS		3RD ANGLE PROJECTION		THIS DRAWING IS CONFIDENTIAL AND THE PROPERTY OF TURCK INC. USE OF THIS DOCUMENT WITHOUT WRITTEN PERMISSION IS PROHIBITED.				3000 CAMPUS DRIVE MINNEAPOLIS, MN 55441 1-800-544-7769 (763) 553-7300 (763) 553-0708 fax www.turck.us	
1. 2. 3. 4.				DRFT RDS DATE 09/03/14		DESCRIPTION		BI2-EG08K-AP6X-0.2-RS4T/S1154	
MATERIAL		SEE NOTES		APVD A.F. SCALE 1=1.0		UNIT OF MEASUREMENT		IDENTIFICATION NO.	
FINISH		SEE NOTES		INCH [ MILLIMETER ]		46694103		REV C	
C UPDATE SPECS		RDS 02/24/21		76535		DO NOT SCALE THIS DRAWING		FILE: 46694103	
REV DESCRIPTION		BY DATE		ECO NO.		CONTACT TURCK FOR MORE INFORMATION		SHEET 1 OF 1	