

SPECIFICATIONS

RATED OPERATING DISTANCE	1.5mm [.059]
MOUNTING MODE	FLUSH
MIN. REPEAT ACCURACY	≤ 2%
TEMPERATURE DRIFT	≤ ±10%
HYSTERESIS	20%
OPERATING TEMPERATURE	-25°C to +70°C (-13°F to +158°F)
OPERATING VOLTAGE	10-30 VDC
RESIDUAL RIPPLE	≤ 10%
DC RATED OPERATIONAL CURRENT	≤150 mA
NO-LOAD CURRENT	≤ 15 mA
RESIDUAL CURRENT	≤ 0.1 mA
RATED INSULATION VOLTAGE	≤ 0.5 kV
SHORT-CIRCUIT PROTECTED	YES
MAX VOLTAGE DROP	≤ 1.8 V
WIRE-BREAKAGE PROTECTION	YES
REVERSE POLARITY PROTECTION	YES
OUTPUT FUNCTION	3-WIRE, NORMALLY OPEN, PNP
SWITCHING FREQUENCY	≤ 3.0 kHz
HOUSING MATERIAL	STAINLESS STEEL 1.4305 (AISI 303)
ACTIVE FACE MATERIAL	PLASTIC, PA6.6
END CAP MATERIAL	PLASTIC, PP
CABLE	∅3.3, LiFY-11Y, TPU
SHOCK RESISTANCE	30 g, 11 ms
VIBRATION RESISTANCE	55 Hz, 1 mm AMPLITUDE (IN ALL 3 PLANES)
DEGREE OF PROTECTION	IP67
SWITCHING STATUS INDICATION	LED: YELLOW

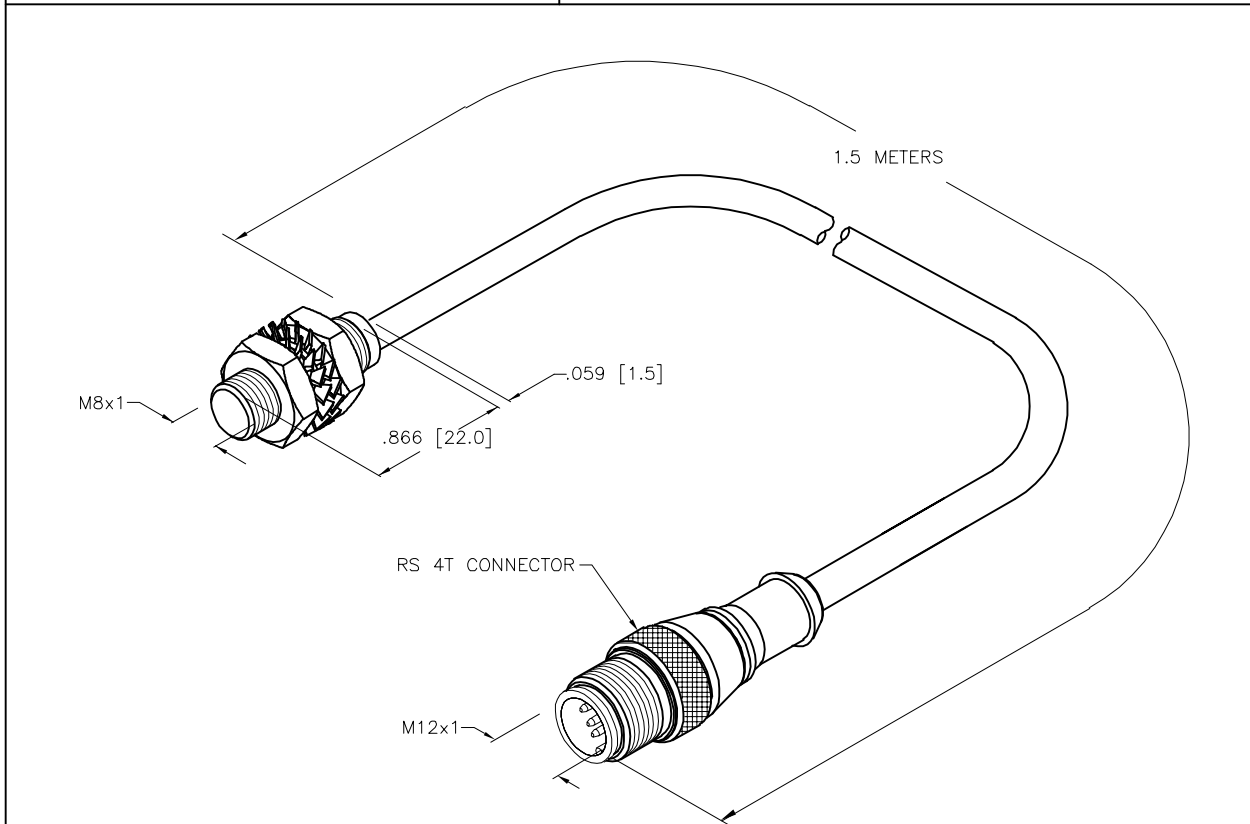

SOURCE DRAWING - FOR REFERENCE ONLY

RELATED DOCUMENTS		3RD ANGLE PROJECTION		THIS DRAWING IS CONFIDENTIAL AND THE PROPERTY OF TURCK INC. USE OF THIS DOCUMENT WITHOUT WRITTEN PERMISSION IS PROHIBITED.				3000 CAMPUS DRIVE MINNEAPOLIS, MN 55441 1-800-544-7769 (763) 553-7300 (763) 553-0708 fax www.turck.us	
1.			ALL DIMENSIONS DISPLAYED ON THIS DRAWING ARE FOR REFERENCE ONLY	DRFT	RDS	DATE	09/10/18	DESCRIPTION B11.5-EG08K-AP6X-1.5-RS4T	
2.				APVD	A.F.	SCALE	1=1.0		
3.		CONTACT TURCK FOR MORE INFORMATION		UNIT OF MEASUREMENT		IDENTIFICATION NO. 4669044		REV B	
4.				<b>INCH [ MILLIMETER ]</b>					
MATERIAL		SEE NOTES		DO NOT SCALE THIS DRAWING		FILE: 4669044		SHEET 1 OF 1	
FINISH		SEE NOTES							
B	UPDATE SPECS	NF	10/30/20	76258					
REV	DESCRIPTION	BY	DATE	ECO NO.					