

SPECIFICATIONS

RATED OPERATING DISTANCE	1.5 mm = .059" (NOMINAL)
MOUNTING MODE	FLUSH
MIN. REPEAT ACCURACY	≤ 2%
TEMPERATURE DRIFT	≤ ± 10%
HYSTERESIS	20%
OPERATING TEMPERATURE	-25°C to +70°C (-13°F to +158°F)
RATED OPERATIONAL VOLTAGE	10-30 VDC
RIPPLE	≤ 10%
RATED OPERATIONAL CURRENT (DC)	≤ 150 mA
NO-LOAD CURRENT	≤ 15 mA
RESIDUAL CURRENT	≤ 0.1 mA
RATED INSULATION VOLTAGE	≤ 0.5 kV
SHORT-CIRCUIT PROTECTED	YES
MAX VOLTAGE DROP	≤ 1.8 V
WIRE BREAKAGE PROTECTION	INCORPORATED
REVERSE POLARITY PROTECTION	INCORPORATED
OUTPUT FUNCTION	3-WIRE, NORMALLY OPEN, PNP
MAX. SWITCHING FREQUENCY	≤ 3.0 kHz
HOUSING MATERIAL	STAINLESS STEEL, 1.4305 (AISI 303)
ACTIVE FACE MATERIAL	PLASTIC, PA6.6
END CAP MATERIAL	PLASTIC, PP
CABLE	∅3.3, LiFY-11Y, TPU
SHOCK RESISTANCE	30 g, 11 ms
VIBRATION RESISTANCE	55 Hz, 1 mm AMPLITUDE (IN ALL 3 PLANES)
DEGREE OF PROTECTION	IP67
SWITCHING STATUS INDICATION	LED: YELLOW

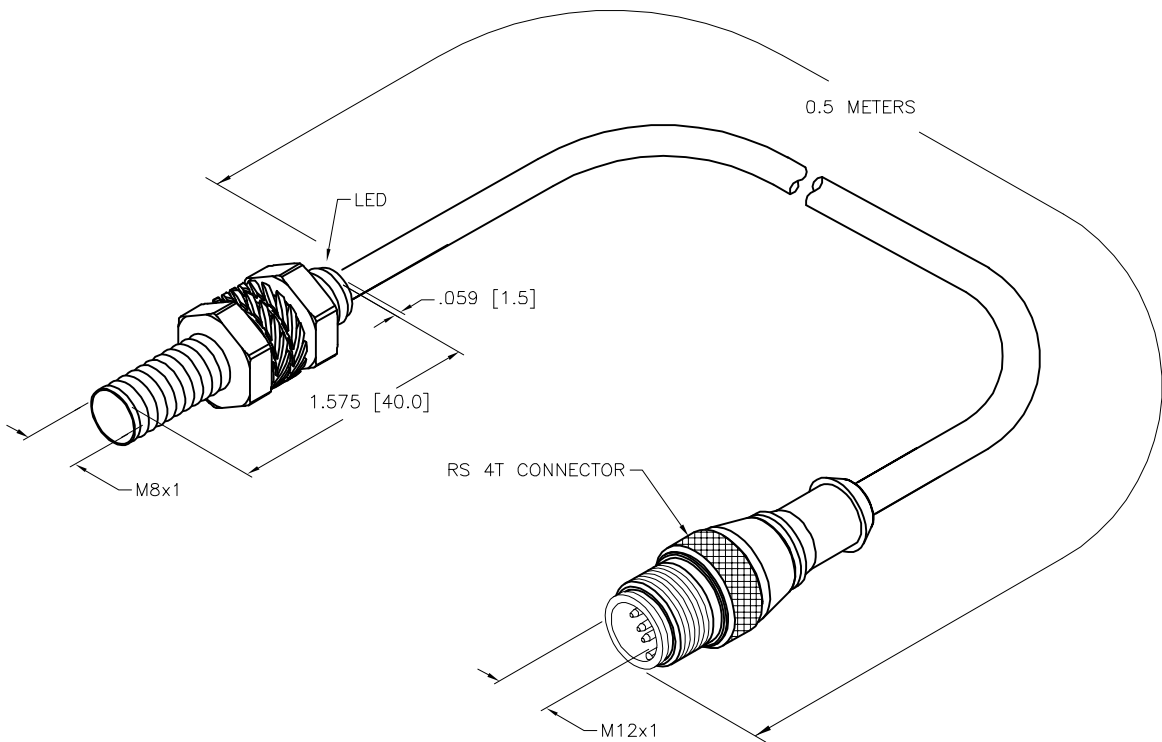

SOURCE DRAWING - FOR REFERENCE ONLY

RELATED DOCUMENTS		3RD ANGLE PROJECTION		THIS DRAWING IS CONFIDENTIAL AND THE PROPERTY OF TURCK INC. USE OF THIS DOCUMENT WITHOUT WRITTEN PERMISSION IS PROHIBITED.		<p>3000 CAMPUS DRIVE MINNEAPOLIS, MN 55441 1-800-544-7769 (763) 553-7300 (763) 553-0708 fax www.turck.us</p>	
1.			<p>ALL DIMENSIONS DISPLAYED ON THIS DRAWING ARE FOR REFERENCE ONLY</p>	DRFT	RDS	DATE	02/02/10
2.				APVD		SCALE	1=1.0
3.		UNIT OF MEASUREMENT				DESCRIPTION	
4.		INCH [MILLIMETER]				BI1.5-EG08-AP6X-0.5-RS4T	
MATERIAL		SEE NOTES		IDENTIFICATION NO.		REV	
FINISH		SEE NOTES		4602270		D	
CONTACT TURCK FOR MORE INFORMATION		DO NOT SCALE THIS DRAWING		FILE: 4602270		SHEET 1 OF 1	

D	UPDATE SPECS	RDS	10/29/20	76257
REV	DESCRIPTION	BY	DATE	ECO NO.