

WIRING DIAGRAM

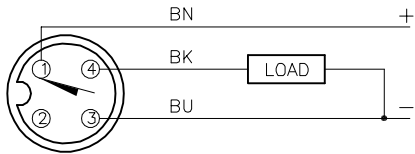

OUTPUT: AP4X2

SHORT-CIRCUIT AND OVERLOAD PROTECTED

T (TOP SENSING)

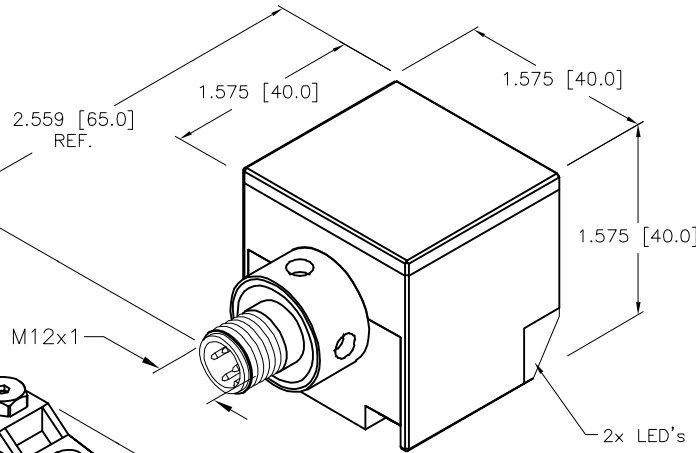
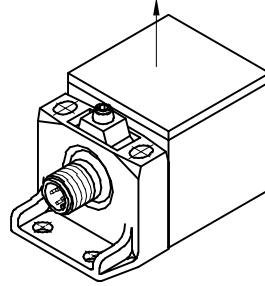

BS-21 CK40 MOUNTING CLAMP
(INCLUDED WITH SENSOR)

M12x1

ø.866 [22.0]

(2x) ø.209 [5.3]

1.496 [38.0]

1.575 [40.0]

.984 [25.0]

SPECIFICATIONS

RATED OPERATING DISTANCE	15 mm = .591"
HYSTERESIS	3-15% (5% TYPICAL)
REPEATABILITY	≤ 2% of RATED OPERATING DISTANCE
TEMPERATURE DRIFT	≤ ±10%
OPERATING TEMPERATURE	-30°C to +85°C (+14°F to +140°F) (w/± 10% TEMP. DRIFT)
OPERATING VOLTAGE	10-65 VDC
RIPPLE	≤ 10%
CONTINUOUS LOAD CURRENT	≤ 200 mA
NO-LOAD CURRENT	≤ 15 mA
RESIDUAL CURRENT	≤ 0.1 mA
MAX. SWITCHING FREQUENCY	≤ 0.15 kHz
RATED INSULATION VOLTAGE	≤ 0.5 kV
OUTPUT FUNCTION	3-WIRE, NORMALLY OPEN, PNP
SHORT-CIRCUIT PROTECTED	YES
MAX. VOLTAGE DROP	≤ 1.8 V
REVERSE POLARITY PROTECTION	INCORPORATED
WIRE-BREAK PROTECTION	INCORPORATED
HOUSING MATERIAL	PLASTIC, PBT-GF30-V0
ACTIVE FACE	PLASTIC, PBT-GF30-V0
VIBRATION	55 Hz, 1 mm AMPLITUDE (IN ALL 3 PLANES)
SHOCK	30 g, 11 ms
PROTECTION	IP68
SUPPLY VOLTAGE INDICATION	LED - GREEN
SWITCHING STATUS INDICATION	LED - YELLOW

SOURCE DRAWING - FOR REFERENCE ONLY

NOTES:

1. UPROX HAS WELD FIELD IMMUNITY, SENSOR IS SUITABLE FOR USE ON RESISTANCE MACHINES.
2. "/S543" DESIGNATES CK40 CABLE SUPPORT CHAMBER IS POTTED.

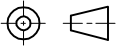
RELATED DOCUMENTS		3RD ANGLE PROJECTION		THIS DRAWING IS CONFIDENTIAL AND THE PROPERTY OF TURCK INC. USE OF THIS DOCUMENT WITHOUT WRITTEN PERMISSION IS PROHIBITED.		 <p>3000 CAMPUS DRIVE MINNEAPOLIS, MN 55441 1-800-544-7769 (763) 553-7300 (763) 553-0708 fax www.turck.us</p>	
1.				DRFT RDS		DATE 01/15/14	
2.				APVD A.F.		SCALE NONE	
3.		ALL DIMENSIONS DISPLAYED ON THIS DRAWING ARE FOR REFERENCE ONLY		UNIT OF MEASUREMENT			
4.				INCH [MILLIMETER]			
MATERIAL		PBT-GF30-V0 PLASTIC HOUSING		DESCRIPTION		B115U-CK40-AP4X2-H1141/S543-T BS 2.1	
FINISH		CONTACT TURCK FOR MORE INFORMATION		IDENTIFICATION NO.		REV	
D UPDATE NOTES		RDS 11/14/22 78117		15380920		D	
REV DESCRIPTION		BY DATE ECO NO.		DO NOT SCALE THIS DRAWING		FILE: 15380920 SHEET 1 OF 1	

D	UPDATE NOTES	RDS	11/14/22	78117
REV	DESCRIPTION	BY	DATE	ECO NO.