

SPECIFICATIONS	
RATED OPERATING DISTANCE	12mm = .472"
MOUNTING MODE	FLUSH
MIN. REPEAT ACCURACY	≤ 2%
TEMPERATURE DRIFT	≤ ±10% ≤ ±20%, ≤ -25°C
HYSTERESIS	3-15%
OPERATING TEMPERATURE	-40°C to +70°C (-40°F to +158°F)
RATED OPERATIONAL VOLTAGE	10-30 VDC
RESIDUAL RIPPLE	≤ 10%
RATED OPERATIONAL CURRENT (AC/DC)	≤ 6000 mA (AC)/≤ 6000 mA (DC)
RATED OUTPUT VOLTAGE (AC/DC)	≤ 28 VAC/≤ 30 VDC
OUTPUT LOAD	≤ 180 W
RESIDUAL CURRENT	≤ 0.1 mA
RATED INSULATION VOLTAGE	≤ 0.5 kV
SURGE CURRENT	≤ 8.0 A (≤ 10.0 ms MAX. 5 Hz)
SHORT-CIRCUIT PROTECTION	NO
MAX. VOLTAGE DROP	≤ 1.8 V
WIRE BREAKAGE PROTECTION	INCORPORATED
REVERSE POLARITY PROTECTION	INCORPORATED
OUTPUT FUNCTION	5-WIRE, COMPLIMENTARY, MOSFET OUTPUT
SMALLEST OPERATING CURRENT	≥ 40 mA
MAX. SWITCHING FREQUENCY	≤ 0.02 kHz
HOUSING MATERIAL	METAL, BRASS/CHROME-PLATED
ACTIVE FACE MATERIAL	PLASTIC, PA12-GF30
END CAP MATERIAL	PLASTIC, TROGAMID T
CABLE	∅7.2, PVC, 5x18 AWG
VIBRATION RESISTANCE	55 Hz, 1 mm AMPLITUDE (IN ALL 3 PLANES)
SHOCK RESISTANCE	30 g, 11 ms
DEGREE OF PROTECTION	IP67
SWITCHING STATUS INDICATION	LED, YELLOW

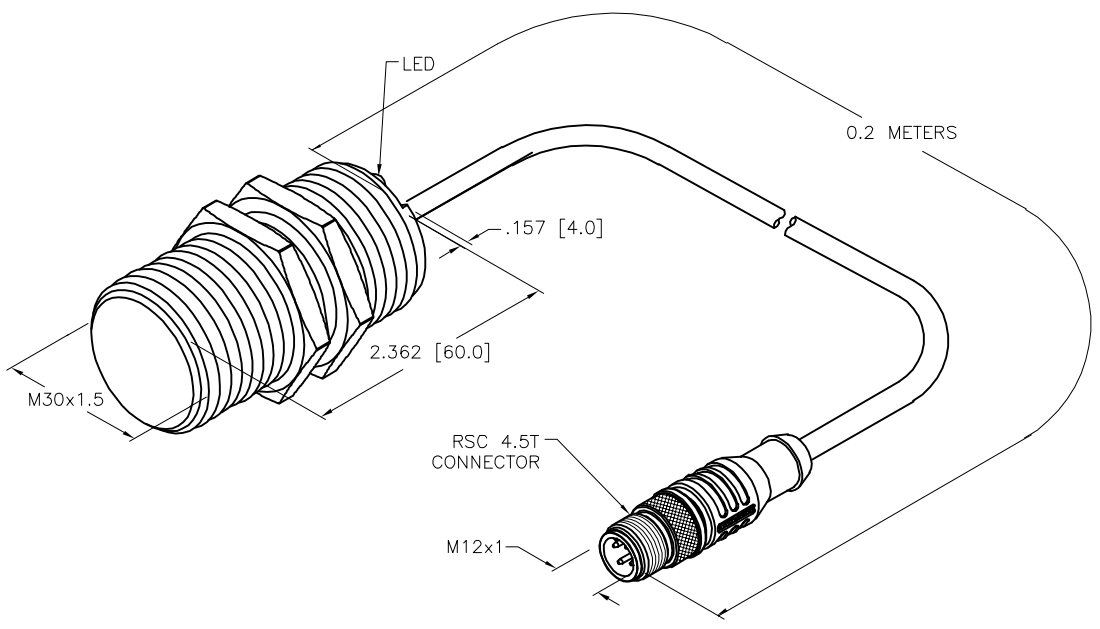

SOURCE DRAWING - FOR REFERENCE ONLY

NOTES:

1. "/S97" DESIGNATES LOW OPERATING TEMPERATURE RATING OF -40°C.

RELATED DOCUMENTS 1. 2. 3. 4.	3RD ANGLE PROJECTION 	THIS DRAWING IS CONFIDENTIAL AND THE PROPERTY OF TURCK INC. USE OF THIS DOCUMENT WITHOUT WRITTEN PERMISSION IS PROHIBITED.		3000 CAMPUS DRIVE MINNEAPOLIS, MN 55441 1-800-544-7769 (763) 553-7300 (763) 553-0708 fax www.turck.us
MATERIAL	ALL DIMENSIONS DISPLAYED ON THIS DRAWING ARE FOR REFERENCE ONLY	DRFT RDS	DATE 06/16/11	DESCRIPTION BI12-G30-VM6/37X/S97-0.2-RSC4.5T
FINISH		APVD	SCALE 1=1.5	
		UNIT OF MEASUREMENT INCH [MILLIMETER]		IDENTIFICATION NO. 1711294
		CONTACT TURCK FOR MORE INFORMATION		REV B
B	UPDATE ID NUMBER PER HARMONIZATION PROJECT	CBM	11/15/17	
REV	DESCRIPTION	BY	DATE	ECO NO.
				DO NOT SCALE THIS DRAWING
				FILE: 1711294
				SHEET 1 OF 1