

WIRING DIAGRAM

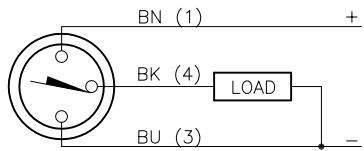

OUTPUT: AP6

SHORT-CIRCUIT AND OVERLOAD PROTECTED

SPECIFICATIONS

RATED OPERATING DISTANCE	1.0 mm [.039"]
MOUNTING MODE	FLUSH
MIN. REPEAT ACCURACY	≤ 2%
TEMPERATURE DRIFT	≤ ±10%
HYSTERESIS	3-15%
AMBIENT TEMPERATURE	-25°C to +70°C (-13°F to +158°F)
OPERATING VOLTAGE	10-30 VDC
RESIDUAL RIPPLE	≤ 10%
DC OPERATIONAL CURRENT	≤ 150 mA
NO-LOAD CURRENT	≤ 15 mA
RESIDUAL CURRENT	≤ 0.1 mA
RATED INSULATION VOLTAGE	≤ 0.5 kV
SHORT-CIRCUIT PROTECTION	YES
MAX. VOLTAGE DROP	≤ 1.8 V
WIRE BREAKAGE PROTECTION	INCORPORATED
REVERSE POLARITY PROTECTION	INCORPORATED
OUTPUT FUNCTION	3-WIRE, NORMALLY OPEN, PNP
MAX. SWITCHING FREQUENCY	≤ 2.0 kHz
HOUSING MATERIAL	PLASTIC, PP-GF20
ACTIVE FACE MATERIAL	PLASTIC, PP-GF20
CABLE	∅2.0, Lif9Y-11Y, TPU, GRAY
VIBRATION RESISTANCE	55 Hz (IN ALL 3 PLANES)
SHOCK RESISTANCE	30 g, 11 ms
DEGREE OF PROTECTION	IP 67

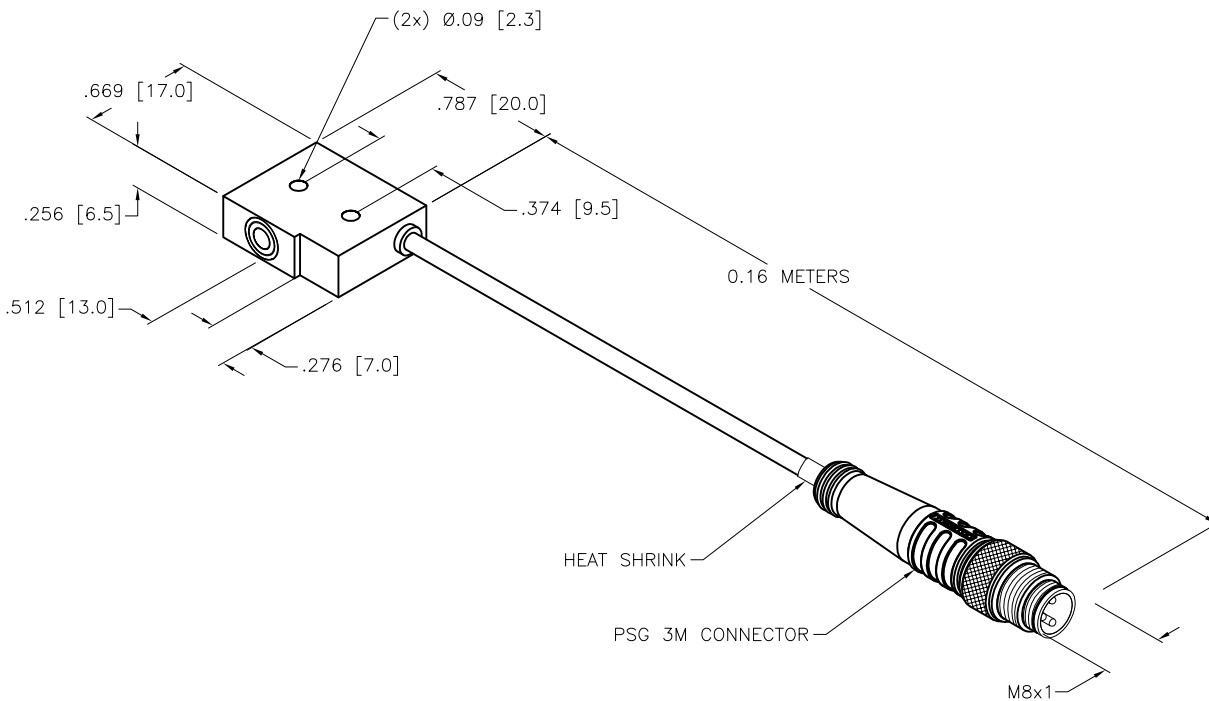

SOURCE DRAWING - FOR REFERENCE ONLY

NOTES:

1. "/S34" DESIGNATES WELD FIELD IMMUNITY.

RELATED DOCUMENTS 1. 2. 3. 4.	3RD ANGLE PROJECTION 	THIS DRAWING IS CONFIDENTIAL AND THE PROPERTY OF TURCK INC. USE OF THIS DOCUMENT WITHOUT WRITTEN PERMISSION IS PROHIBITED.		3000 CAMPUS DRIVE MINNEAPOLIS, MN 55441 1-800-544-7769 (763) 553-7300 (763) 553-0708 fax www.turck.us	
	MATERIAL SEE SPECIFICATIONS	DRFT RDS APVD	DATE 03/10/09 SCALE 1=1.0	DESCRIPTION B11-Q6.5-AP6-0.16M-PSG3M/S34	
FINISH SEE SPECIFICATIONS	ALL DIMENSIONS DISPLAYED ON THIS DRAWING ARE FOR REFERENCE ONLY	UNIT OF MEASUREMENT <b>INCH [ MILLIMETER ]</b>		IDENTIFICATION NO. 4613499	REV E
E UPDATE ID NUMBER PER HARMONIZATION PROJECT	CBM 11/06/17	DO NOT SCALE THIS DRAWING		FILE: 4613499	SHEET 1 OF 1
REV DESCRIPTION	BY DATE ECO NO.				