

WIRING DIAGRAM

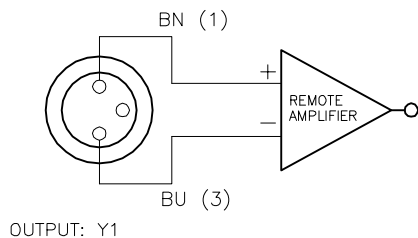

SPECIFICATIONS

RATED OPERATING DISTANCE	1mm [.039"]
MOUNTING MODE	FLUSH
MIN. REPEAT ACCURACY	≤ 2%
TEMPERATURE DRIFT	≤ ± 10%
HYSTERESIS	1-10%
OPERATING TEMPERATURE	-25°C to +70°C (-13°F to +158°F)
OUTPUT FUNCTION	2-WIRE, NAMUR
SWITCHING FREQUENCY	≤ 5.0 kHz
OPERATING VOLTAGE	8.2 VDC NOMINAL
NON-ACTUATED CURRENT CONSUMPTION	≥ 2.1 mA
ACTUATED CURRENT CONSUMPTION	≤ 1.2 mA
APPROVAL ACCORDING TO:	KEMA 02 ATEX 1090X
INTERNAL INDUCTANCE (L _i)/CAPACITANCE (C _i)	150 nF/150 μH * VALUES FOR PRE-ASSEMBLED CABLES UP TO 30M
MARKING ON THE DEVICE	⊕ II 2 G EEx ia IIC T6 (max. U _i = 20 V, I _i = 60 mA, P _i = 80 mW)
HOUSING MATERIAL	METAL, AISI 316L
ACTIVE FACE MATERIAL	PLASTIC, PA12-GF30
CABLE/COLOR/MATERIAL	ø3.0/BLUE/PVC
SHOCK RESISTANCE	30 g, 11 ms
VIBRATION RESISTANCE	55 Hz, 1 mm AMPLITUDE (IN ALL 3 PLANES)
DEGREE OF PROTECTION	IP67

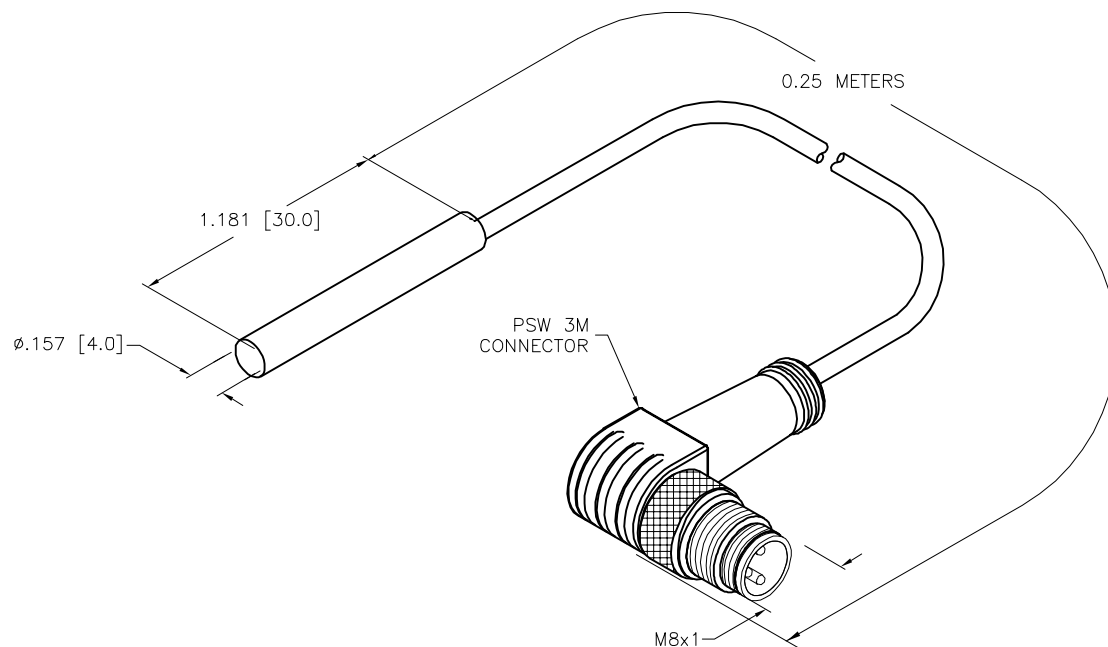

SOURCE DRAWING - FOR REFERENCE ONLY

NOTES:

1. "/CS10011" DESIGNATES EXTENSION CORDSETS AND SENSOR MOLD-ONS WITH A TIGHTER TOLERANCE -0/+12.5MM (MAXIMUM LENGTH IS 1.7 METERS.)

RELATED DOCUMENTS 1. 2. 3. 4.	3RD ANGLE PROJECTION 	THIS DRAWING IS CONFIDENTIAL AND THE PROPERTY OF TURCK INC. USE OF THIS DOCUMENT WITHOUT WRITTEN PERMISSION IS PROHIBITED.		3000 CAMPUS DRIVE MINNEAPOLIS, MN 55441 1-800-544-7769 (763) 553-7300 (763) 553-0708 fax www.turck.us	
	MATERIAL SEE NOTES	ALL DIMENSIONS DISPLAYED ON THIS DRAWING ARE FOR REFERENCE ONLY CONTACT TURCK FOR MORE INFORMATION	DRFT AS APVD A.F.	DATE 10/14/25 SCALE 1=.8	DESCRIPTION B11-EH04-Y1-0.25-PSW3M/CS10011
FINISH SEE NOTES		UNIT OF MEASUREMENT INCH [MILLIMETER]		IDENTIFICATION NO. 200017228	REV A
A DRAWING RELEASE AS 10/15/25	BY DATE ECO NO.	DO NOT SCALE THIS DRAWING		FILE: 200017228	SHEET 1 OF 1

