

WIRING DIAGRAM

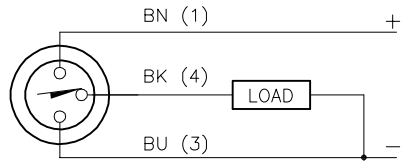

OUTPUT: AP6X

SHORT-CIRCUIT AND OVERLOAD PROTECTED

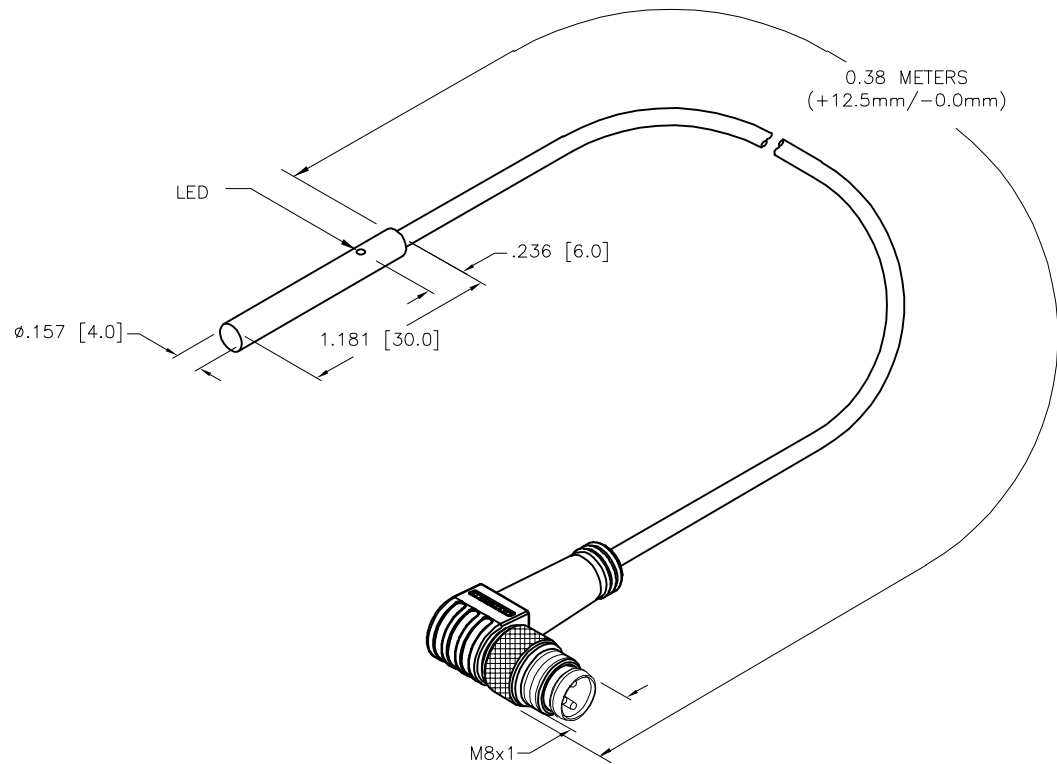

SPECIFICATIONS

RATED OPERATING DISTANCE	1mm = .039"
MOUNTING MODE	FLUSH
MIN. REPEAT ACCURACY	≤ 2%
TEMPERATURE DRIFT	≤ ±10%
HYSTERESIS	3-15%
OPERATING TEMPERATURE	-25°C to +70°C (-13°F to +158°F)
RATED OPERATIONAL VOLTAGE	10-30 VDC
RESIDUAL RIPPLE	≤ 10%
DC RATED OPERATIONAL CURRENT	≤ 100 mA
NO-LOAD CURRENT	≤ 15 mA
RESIDUAL CURRENT	≤ 0.1 mA
RATED INSULATION VOLTAGE	≤ 0.5 kV
SHORT-CIRCUIT PROTECTION	INCORPORATED
MAX. VOLTAGE DROP	≤ 1.8 V
WIRE BREAKAGE PROTECTION	INCORPORATED
REVERSE POLARITY PROTECTION	INCORPORATED
OUTPUT FUNCTION	3-WIRE, NORMALLY OPEN, PNP
MAX. SWITCHING FREQUENCY	≤ 3 kHz
HOUSING MATERIAL	METAL, A4 1.4404 (AISI 316L)
ACTIVE FACE	PLASTIC, PA12-GF20
END CAP	PLASTIC, TROGAMID T
CABLE	Ø3.0, TPU
VIBRATION RESISTANCE	55 Hz, 1 mm AMPLITUDE (IN ALL 3 PLANES)
SHOCK RESISTANCE	30 g, 11 ms
DEGREE OF PROTECTION	IP67
SWITCHING STATUS INDICATION	LED, YELLOW

SOURCE DRAWING - FOR REFERENCE ONLY

NOTES:

1. "/S1367" DESIGNATES LEGACY SENSOR DESIGN PRIOR TO 2020.
2. "/CS10011" DESIGNATES SENSOR MOLD-ON WITH TIGHTER TOLERANCE. +12.5mm/-0.0mm

RELATED DOCUMENTS		3RD ANGLE PROJECTION		THIS DRAWING IS CONFIDENTIAL AND THE PROPERTY OF TURCK INC. USE OF THIS DOCUMENT WITHOUT WRITTEN PERMISSION IS PROHIBITED.		<p>3000 CAMPUS DRIVE MINNEAPOLIS, MN 55441 1-800-544-7769 (763) 553-7300 (763) 553-0708 fax www.turck.us</p>	
1.				DRFT RDS		DATE 05/11/21	
2.				APVD A.F.		SCALE 1=1.0	
3.		ALL DIMENSIONS DISPLAYED ON THIS DRAWING ARE FOR REFERENCE ONLY		UNIT OF MEASUREMENT		DESCRIPTION	
4.				INCH [MILLIMETER]		B11-EH04-AP6X-0.38-PSW3M/S1367/CS10011	
MATERIAL		CONTACT TURCK FOR MORE INFORMATION		IDENTIFICATION NO.		REV	
FINISH				100032579		A	
DO NOT SCALE THIS DRAWING		FILE: 100032579		SHEET 1 OF 1			

A	DRAWING RELEASE	RDS	08/02/21	
REV	DESCRIPTION	BY	DATE	ECO NO.