

WIRING DIAGRAM

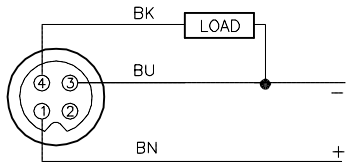

OUTPUT: AP6X

SHORT-CIRCUIT AND OVERLOAD PROTECTED

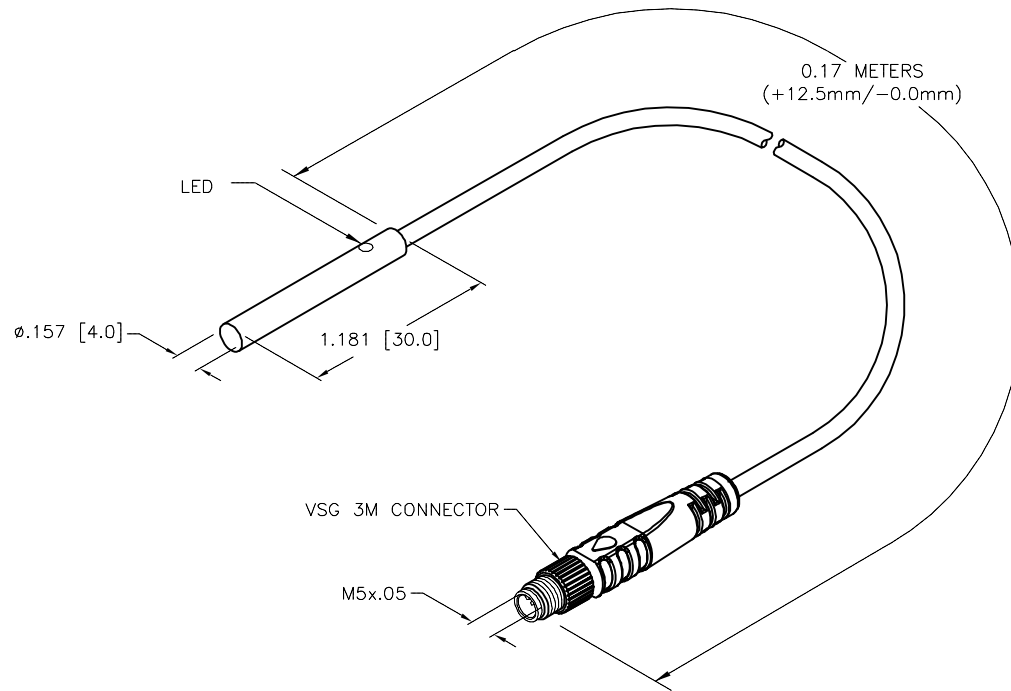

SPECIFICATIONS

RATED OPERATING DISTANCE	1mm = .039"
MOUNTING MODE	FLUSH
MIN. REPEAT ACCURACY	≤ 2%
TEMPERATURE DRIFT	≤ ±10%
HYSTERESIS (SWITCHING DISTANCE)	3-15%
OPERATING TEMPERATURE	-25°C to +70°C (-13°F to +158°F)
RATED OPERATIONAL VOLTAGE	10-30 VDC
MAX. RIPPLE	≤ 10%
DC RATED OPERATIONAL CURRENT	≤ 100 mA
NO-LOAD CURRENT	≤ 15 mA
MAX. OFF-STATE CURRENT	≤ 0.1 mA
RATED INSULATION VOLTAGE	≤ 0.5 kV
SHORT-CIRCUIT PROTECTION	INCORPORATED
MAX. VOLTAGE DROP	≤ 1.8 V
WIRE BREAKAGE PROTECTION	INCORPORATED
REVERSE POLARITY PROTECTION	INCORPORATED
OUTPUT FUNCTION	3-WIRE, NORMALLY OPEN, PNP
MAX. SWITCHING FREQUENCY	≤ 3 kHz
HOUSING MATERIAL	METAL, A4 1.4404 (AISI 316L)
ACTIVE FACE	PLASTIC, PA12-GF20
END CAP	PLASTIC, TROGAMID T
CABLE	$\phi$ 3.0, LiYY-11Y, TPU
VIBRATION RESISTANCE	55 Hz, 1 mm AMPLITUDE (IN ALL 3 PLANES)
SHOCK RESISTANCE	30 g, 11 ms
DEGREE OF PROTECTION	IP67
SWITCHING STATUS INDICATION	LED, YELLOW

SOURCE DRAWING - FOR REFERENCE ONLY

NOTES:

1. "/S1367" DESIGNATES LEGACY SENSOR DESIGN PRIOR TO 2020.
2. "/CS10011" DESIGNATES EXTENSION CORDSETS AND SENSOR MOLD-ONS WITH A TIGHTER TOLERANCE -0/+12.5MM (MAXIMUM LENGTH IS 1.2 METERS.)

RELATED DOCUMENTS 1. 2. 3. 4.	3RD ANGLE PROJECTION 	THIS DRAWING IS CONFIDENTIAL AND THE PROPERTY OF TURCK INC. USE OF THIS DOCUMENT WITHOUT WRITTEN PERMISSION IS PROHIBITED.		3000 CAMPUS DRIVE MINNEAPOLIS, MN 55441 1-800-544-7769 (763) 553-7300 (763) 553-0708 fax www.turck.us	
	MATERIAL	DRFT RDS	DATE 11/12/09	DESCRIPTION BI1-EH04-AP6X-0.17-VSG3M/S1367/CS10011	
FINISH	ALL DIMENSIONS DISPLAYED ON THIS DRAWING ARE FOR REFERENCE ONLY	APVD	SCALE 1=1.0	IDENTIFICATION NO. 4609575	
CONTACT TURCK FOR MORE INFORMATION		UNIT OF MEASUREMENT <b>INCH [ MILLIMETER ]</b>		REV D	
DO NOT SCALE THIS DRAWING		FILE: 4609575		SHEET 1 OF 1	
D	UPDATE NOTES AND DESCRIPTION	RDS	09/10/20	500000001920	
REV	DESCRIPTION	BY	DATE	ECO NO.	

D	UPDATE NOTES AND DESCRIPTION	RDS	09/10/20	500000001920	
REV	DESCRIPTION	BY	DATE	ECO NO.	