

SPECIFICATIONS

| | |
|------------------------------|-----------------------------------------|
| RATED OPERATING DISTANCE | 1.0 mm = .039" (NOMINAL) |
| MOUNTING MODE | FLUSH |
| MIN. REPEAT ACCURACY | ≤ 2% |
| TEMPERATURE DRIFT | ≤ ± 10% |
| HYSTERESIS | 10% |
| OPERATING TEMPERATURE | -25°C to +70°C (-13°F to +158°F) |
| RATED OPERATIONAL VOLTAGE | 10-30 VDC |
| RESIDUAL RIPPLE | ≤ 10% |
| DC RATED OPERATIONAL CURRENT | ≤ 100 mA |
| NO-LOAD CURRENT | ≤ 15 mA |
| RESIDUAL CURRENT | ≤ 0.1 mA |
| RATED INSULATION VOLTAGE | ≤ 0.5 kV |
| SHORT-CIRCUIT PROTECTED | YES |
| MAX VOLTAGE DROP | ≤ 1.8 V |
| WIRE BREAKAGE PROTECTION | INCORPORATED |
| REVERSE POLARITY PROTECTION | INCORPORATED |
| OUTPUT FUNCTION | 3-WIRE, NORMALLY OPEN, PNP |
| MAX. SWITCHING FREQUENCY | ≤ 2.0 kHz |
| HOUSING MATERIAL | STAINLESS STEEL, 1.4305 (AISI 303) |
| ACTIVE FACE MATERIAL | PLASTIC, PA6.6 |
| CABLE | ∅3.3, LIFY-11Y, TPU |
| SHOCK RESISTANCE | 30 g, 11 ms |
| VIBRATION RESISTANCE | 55 Hz, 1 mm AMPLITUDE (IN ALL 3 PLANES) |
| DEGREE OF PROTECTION | IP67 |
| SWITCHING STATUS INDICATION | LED: YELLOW |

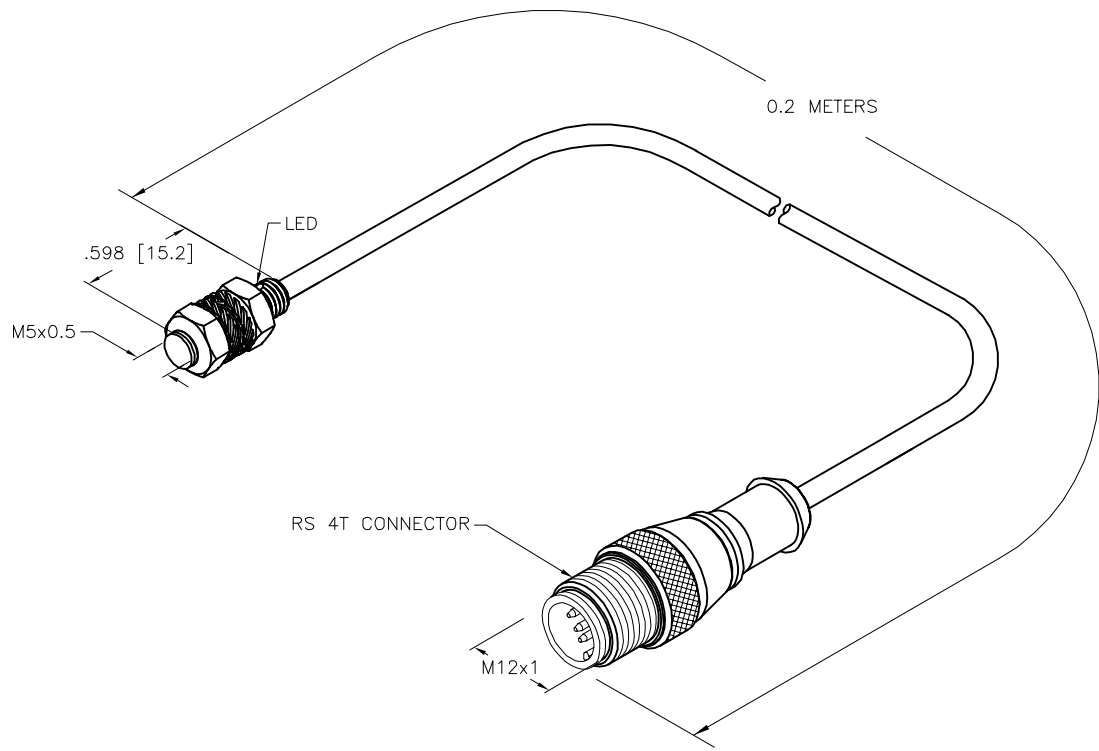

SOURCE DRAWING - FOR REFERENCE ONLY

| | | | | | |
|-------------------------------------------|-----------------------------------------------------------------|----------------------------------------------------------------------------------------------------------------------------|------------------------------|----------------------------------------------------------------------------------------------------------------------|----------|
| RELATED DOCUMENTS 1. 2. 3. 4. | 3RD ANGLE PROJECTION | THIS DRAWING IS CONFIDENTIAL AND THE PROPERTY OF TURCK INC. USE OF THIS DOCUMENT WITHOUT WRITTEN PERMISSION IS PROHIBITED. | | 3000 CAMPUS DRIVE MINNEAPOLIS, MN 55441 1-800-544-7769 (763) 553-7300 (763) 553-0708 fax www.turck.us | |
| | MATERIAL SEE NOTES | DRFT RDS APVD A.F. | DATE 11/19/14 SCALE 1=1.0 | DESCRIPTION BI1-EG05K-AP6X-0.2-RS4T | |
| FINISH SEE NOTES | ALL DIMENSIONS DISPLAYED ON THIS DRAWING ARE FOR REFERENCE ONLY | UNIT OF MEASUREMENT INCH [MILLIMETER] | | IDENTIFICATION NO. 46097650 | REV C |
| C UPDATE SPECS AND BARREL | RDS 10/30/20 | 76261 | DO NOT SCALE THIS DRAWING | | |
| REV DESCRIPTION | BY DATE | ECO NO. | FILE: 46097650 | SHEET 1 OF 1 | |