

WIRING DIAGRAM

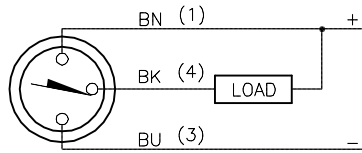

OUTPUT: AP6X

SHORT-CIRCUIT AND OVERLOAD PROTECTED

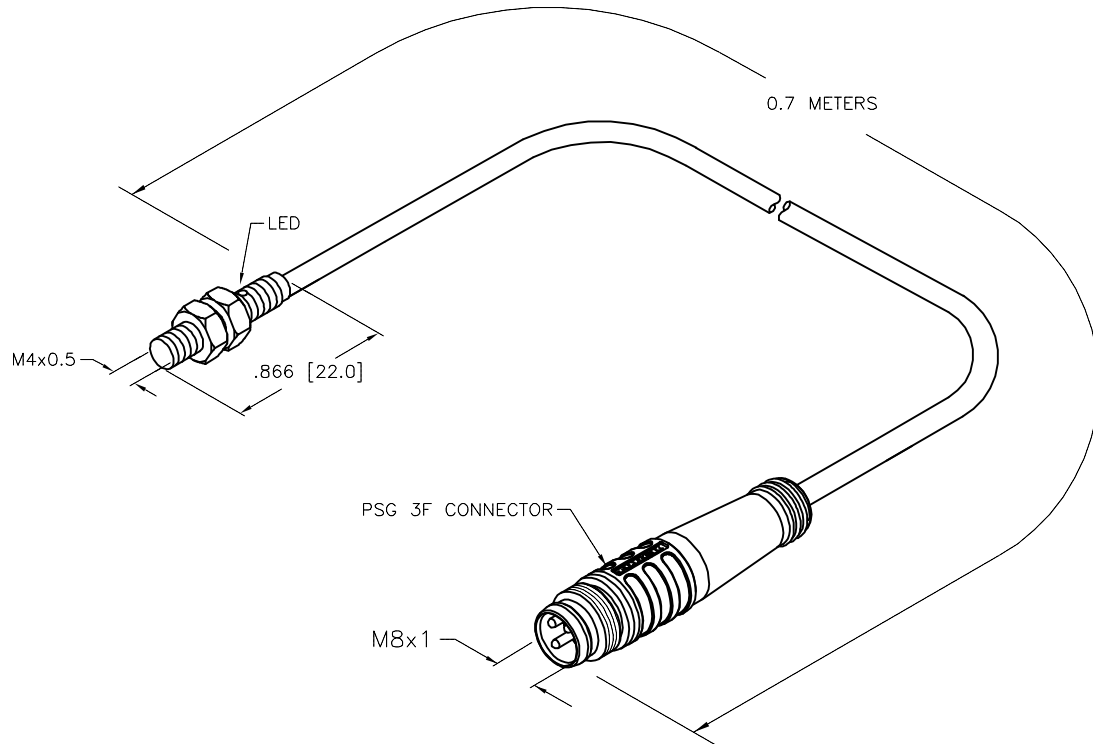

SPECIFICATIONS

RATED OPERATING DISTANCE	1.0 mm = .039" (NOMINAL)
MOUNTING MODE	FLUSH
MIN. REPEAT ACCURACY	≤ 2%
TEMPERATURE DRIFT	≤ ± 10%
HYSTERESIS	3-15%
OPERATING TEMPERATURE	-25°C to +70°C (-13°F to +158°F)
RATED OPERATIONAL VOLTAGE	10-30 VDC
RESIDUAL RIPPLE	≤ 20%
DC RATED OPERATIONAL CURRENT	≤ 100 mA
NO-LOAD CURRENT	≤ 10 mA
RESIDUAL CURRENT	≤ 0.1 mA
RATED INSULATION VOLTAGE	≤ 0.5 kV
SHORT-CIRCUIT PROTECTED	YES
MAX VOLTAGE DROP	≤ 0.5kV
WIRE BREAKAGE PROTECTION	INCORPORATED
REVERSE POLARITY PROTECTION	INCORPORATED
OUTPUT FUNCTION	3-WIRE, NORMALLY OPEN, PNP
MAX. SWITCHING FREQUENCY	≤ 3.0 kHz
HOUSING MATERIAL	STAINLESS STEEL 1.4427
ACTIVE FACE MATERIAL	PLASTIC, POLYESTER
CABLE	Ø3.0, LiYY-11Y, PUR
SHOCK RESISTANCE	30 g, 11 ms
VIBRATION RESISTANCE	55 Hz, 1 mm AMPLITUDE (IN ALL 3 PLANES)
DEGREE OF PROTECTION	IP67
SWITCHING STATUS INDICATION	LED: YELLOW

SOURCE DRAWING - FOR REFERENCE ONLY

RELATED DOCUMENTS 1. 2. 3. 4.	3RD ANGLE PROJECTION 	THIS DRAWING IS CONFIDENTIAL AND THE PROPERTY OF TURCK INC. USE OF THIS DOCUMENT WITHOUT WRITTEN PERMISSION IS PROHIBITED.		3000 CAMPUS DRIVE MINNEAPOLIS, MN 55441 1-800-544-7769 (763) 553-7300 (763) 553-0708 fax www.turck.us	
	MATERIAL SEE NOTES	ALL DIMENSIONS DISPLAYED ON THIS DRAWING ARE FOR REFERENCE ONLY	DRFT NF DATE 05/31/17	APVD A.F. SCALE 1=1.0	DESCRIPTION BI1-EG04-AP6X-0.7-PSG3F
FINISH SEE NOTES	CONTACT TURCK FOR MORE INFORMATION	UNIT OF MEASUREMENT INCH [MILLIMETER]		IDENTIFICATION NO. 1619895	REV B
B UPDATE DESCRIPTION RDS 10/06/17 62567	REV DESCRIPTION BY DATE ECO NO.	DO NOT SCALE THIS DRAWING		FILE: 1619895	SHEET 1 OF 1