

WIRING DIAGRAM

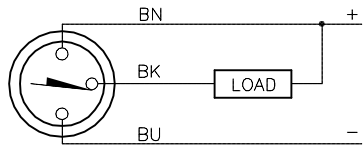

OUTPUT: AN6X2

SHORT-CIRCUIT AND OVERLOAD PROTECTED

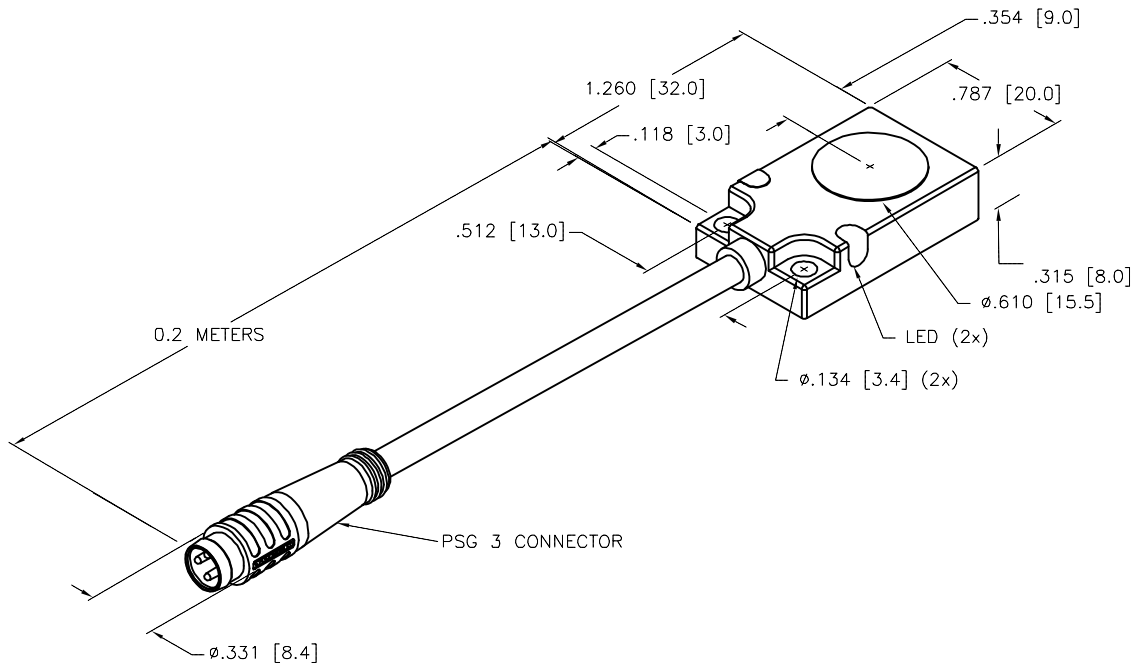

CABLE LENGTH	TOLERANCE*
ALL LENGTHS	+ 4% (OR 50mm) OF LENGTH - 0% (OR 0mm) OF LENGTH WHICHEVER IS GREATER
STRIP LENGTH	TOLERANCE*
0-7mm	±0.5mm
8-29mm	±1.0mm
30-49mm	±2.0mm
50-69mm	±3.0mm
70-100mm	±4.0mm
OVER 100mm	±5.0mm

*UNLESS OTHERWISE SPECIFIED

NOTES:

1. "/S250" DESIGNATES CAPACITIVE SENSOR WITH FIXED CALIBRATION.

SPECIFICATIONS

RATED OPERATING DISTANCE	5mm = .197" (NOMINAL)
MOUNTING MODE	FLUSH or NON-FLUSH
TEMPERATURE DRIFT	≤±20%
HYSTERESIS	2-20%
MIN. REPEAT ACCURACY	≤ 2%
OPERATING TEMPERATURE	-25°C to +70°C (-13°F to +158°F)
RATED OPERATIONAL VOLTAGE	10-30 VDC
RESIDUAL RIPPLE	≤10%
DC RATED OPERATIONAL CURRENT	≤ 200 mA
NO-LOAD CURRENT	≤ 15 mA
RESIDUAL CURRENT	≤ 0.1 mA
MAX. SWITCHING FREQUENCY	≤ 0.1 kHz
RATED INSULATION VOLTAGE	≤ 0.5 kV
OUTPUT FUNCTION	NORMALLY OPEN, 3-WIRE, NPN
SHORT-CIRCUIT PROTECTED	YES
MAX. VOLTAGE DROP	≤ 1.8 V
REVERSE POLARITY PROTECTION	INCORPORATED
WIRE-BREAK PROTECTION	INCORPORATED
HOUSING MATERIAL	METAL, GD-ZN, BLACK
ACTIVE FACE MATERIAL	PLASTIC, PA12-GF30
CABLE	∅4.0, LifYY, PVC
SHOCK	30 g, 11 ms
VIBRATION	55 Hz, 1 mm AMPLITUDE (IN ALL 3 PLANES)
DEGREE OF PROTECTION	IP67
OPERATING VOLTAGE DISPLAY	LED: GREEN
SWITCHING STATUS INDICATION	LED: YELLOW

SOURCE DRAWING - FOR REFERENCE ONLY

RELATED DOCUMENTS	3RD ANGLE PROJECTION	THIS DRAWING IS CONFIDENTIAL AND THE PROPERTY OF TURCK INC. USE OF THIS DOCUMENT WITHOUT WRITTEN PERMISSION IS PROHIBITED.		TURCK INC High Technology Sensors and Automation Controls 3000 CAMPUS DRIVE MINNEAPOLIS, MN 55441 1-800-544-7769 (763) 553-7300 (763) 553-0708 fax turck.com	
1.		DRFT	DK	DATE	10/30/08
2.		APVD		SCALE	1=1.0
3.	ALL DIMENSIONS DISPLAYED ON THIS DRAWING ARE FOR REFERENCE ONLY CONTACT TURCK FOR MORE INFORMATION	UNIT OF MEASUREMENT		DESCRIPTION	
4.		INCH [MILLIMETER]		BC 5-Q08-AN6X2-0.2M-PSG 3/S250	
MATERIAL		DO NOT SCALE THIS DRAWING		IDENTIFICATION NO.	S2620174
FINISH		FILE: S2620174		REV	C

C	UPDATE CABLE O.D.	NF	03/18/16	54015
REV	DESCRIPTION	BY	DATE	ECO NO.