

# excom I/O System

## Output Module, Analog, HART, 4-channel

### AOH401EX

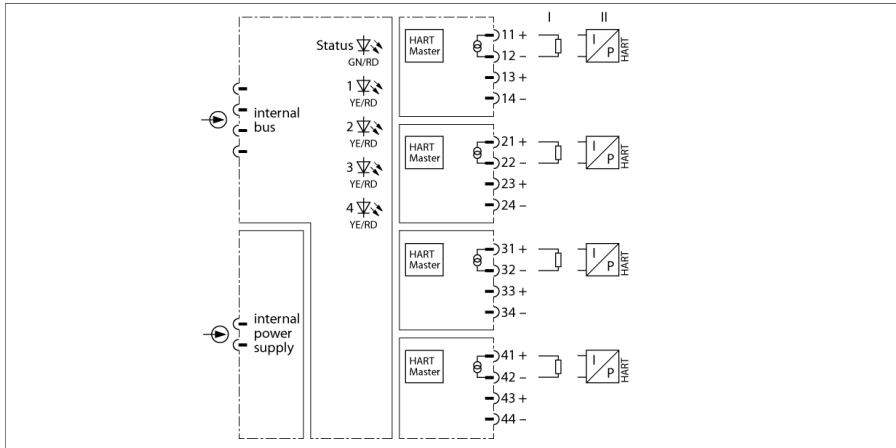

The output module AOH401Ex is designed for the connection of analog actuators such as control valves or process indicators.

The module is functionally compatible with input modules AO40Ex and AOH40EX. In addition, the outputs are galvanically isolated from each other.

The analog value of 0...21 mA is digitized as a number between 0 and 21,000 and transferred to the host system. This corresponds to 1 µA per digit.

HART-compatible actuators that communicate directly with the relevant HART controller can be connected to the module. HART multiplexing is thus no longer necessary and a higher data throughput is achieved.

Up to 8 HART variables (max. 4 per channel) can be transmitted via the cyclic user data to the host system. Acyclic data exchange provides advanced communication options such as the diagnostics and parameterization of HART field devices.

The setting of parameters is initiated solely by the host system. The following parameters can be set for each channel:

- Short circuit monitoring
- Wire-break monitoring
- Substitute value strategy
- HART status/measuring range
- HART variables

- Output module for the connection of analog actuators
- Transmission of HART data
- One HART controller per channel for faster access to HART data
- Complete galvanic isolation

## Dimensions

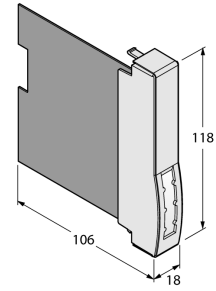

Type	AOH401EX
ID	6884267
Supply voltage	Via module rack, central power supply module
Power consumption	≤ 3 W
Power dissipation	≤ 1.5 W
Galvanic isolation	Complete galvanic isolation
Number of channels	4

Output circuits	Intrinsically safe acc. to EN 60079-11 0/4...22 mA
No-load voltage	18 VDC
HART impedance	> 240 Ω
External load	≤ 680 Ω
Short circuit	< 50 Ω (only with "live zero")
Wire break	< 2 mA (only with "live zero")

Reference temperature	25 °C
Resolution	1 μA / digit
Measuring accuracy (including linearity, hysteresis and repeatability)	≤ 0.06 % of full scale
Temperature drift	≤ 0.0025 % of full scale/K
Rise time/fall time	≤ 40 ms (10...90 %)
Max. measurement tolerance under EMC influence	≤ 0.06 % of full scale with shielded signal cable ≤ 1 % of full scale with unshielded signal cable

Ex approval acc. to conformity certificate	IECEx PTB 18.0034
Ex approval acc. to conformity certificate	PTB 18 ATEX 2003
Device designation	Ⓢ II 2(1) G Ex ib [ia Ga] IIC T4 Gb
Device marking	Ⓢ II (1) D [Ex ia Da] IIIC

Displays/Operating elements	
Operational readiness	1 × green/red
State/ Fault	4 × red/yellow

Housing material	Plastic
Connection mode	module, plugged on rack
Protection class	IP20
Ambient temperature	-20...+70 °C
Relative humidity	≤ 93 % at 40 °C acc. to IEC 60068-2-78
Vibration test	Acc. to IEC 60068-2-6
Shock test	Acc. to IEC 60068-2-27
EMC	Acc. to EN 61326-1 Acc. to Namur NE21
MTTF	33 years acc. to SN 29500 (Ed. 99) 40 °C
Dimensions	18 x 118 x 106 mm

Approvals	ATEX cFMus cFM IECEX CCC INMETRO KOSHA EAC Ex CMI UKCA CE
-----------	---